

# User Manual

## YouthPOWER 8KW all-in-one user manual







**Please comply with all warnings and operating instructions in this manual strictly. Save this manual properly and read carefully the following instructions before installing the unit. Do not operate this unit before reading through all safety information and operating instructions carefully.**



# 1. System diagram

- System diagram structure
- Battery system design

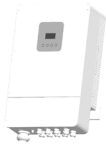
This system consists of one 8KW inverter and two 51.2V200Ah modules in parallel.

Serial	Description	Details	Rated Voltage (V)	Rated Capacity (Ah)	Power	Structure	Remarks
1	Cell		3.2	100	320	2P1S	
2	Battery Pack		51.2	200	9600	2P16S	2PCS
4	<b>Inverter 8kw</b>		/	/	/	/	1PCS
5	The cabinet		/	/	/	/	1PCS

## 1.3.Safety Gear

			
Insulated gloves	Safety goggles	Safety shoes	Helmet



### **WARNING**

**Insulating gloves should be worn during the wiring process to avoid accidental contact with hardware contacts and prevent safety risks.**

## 2. Battery module introduction 电池模组介绍

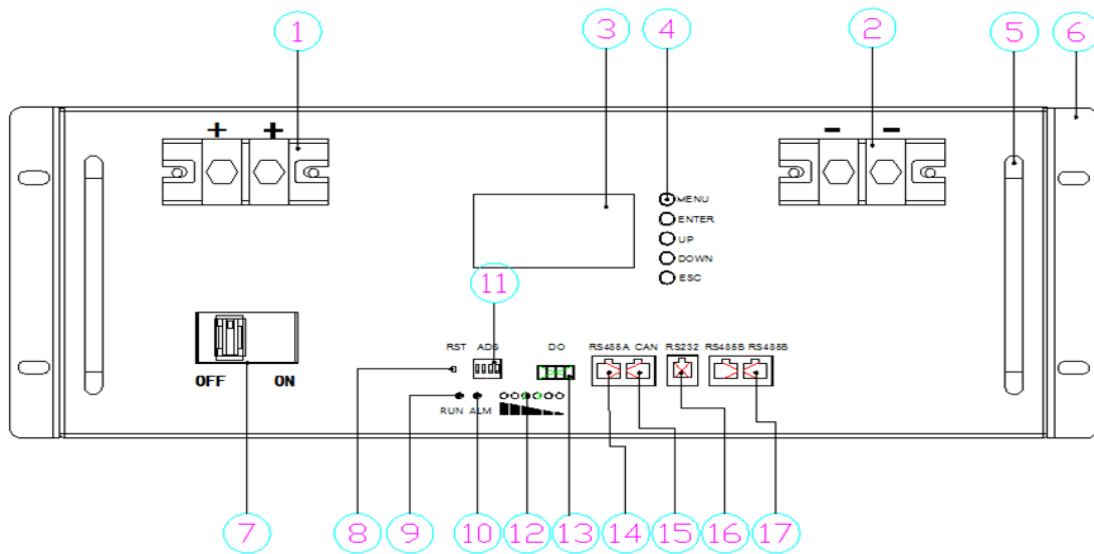

No.	Item	Functional Description	Remark
1	Battery +	Positive terminal	
2	Battery -	Negative terminal	
3	LCD		
4	KEY		
5	Handle		
6	Hanger		For mounting the battery pack
7	Switch	ON/OFF	
8	RST	On/OFF /Reset button	
9	RUN	Working indicator light	Display state information
10	ALM	ALM alarm indicator light	Red-trouble-light on
11	ADS	Battery address dialer	Display connection address
12	CAPACITY	Capacity volume indicator	Display the battery's capacity
13	Dry contact	DO	Normal close
14	RS485	RS485 communication interface	RS485connection port-A
15	CAN port	CAN	CAN communication port
16	RS232 port	RS232	RS232 communication port
17	RS485 port	RS485B	

### 3.SOC Indicator & Status Indicator Guides

●Chart 1: Battery Status

Status	Normal/ Warning/ Protection	RUN	ALM		Capacity LED					Description	
Shut Down	Shut down	OFF	OFF	OFF	OFF	OFF	OFF	OFF	OFF	OFF	All OFF
Standby	Normal	Flash	OFF	OFF	OFF	OFF	OFF	OFF	OFF	OFF	Standby
Charge	Normal	ON	OFF	Based on capacity							
	Warning	ON	Flash								
	Protection	ON	ON								
Discharge	Normal	ON	OFF	Based on capacity							
	Warning	ON	Flash								
	Protection	OFF	ON								
Fault	Protection	OFF	ON	OFF	OFF	OFF	OFF	OFF	OFF	OFF	Stop charging or discharging

●Chart 2: Battery Capacity

Status		Charging						Discharging					
Capacity LED Indicator		L6	L5	L4	L3	L2	L1	L6	L5	L4	L3	L2	L1
Capacity	0~16.6%	OFF	OFF	OFF	OFF	OFF	Flash	OFF	OFF	OFF	OFF	OFF	NO
	16.6~32.2%	OFF	OFF	OFF	OFF	Flash	ON	OFF	OFF	OFF	OFF	NO	NO
	32.2~49.8%	OFF	OFF	OFF	Flash	ON	ON	OFF	OFF	OFF	NO	NO	NO
	49.8~66.4%	OFF	OFF	Flash	ON	ON	ON	OFF	OFF	NO	NO	NO	NO
	66.4~83%	OFF	Flash	ON	ON	ON	ON	OFF	NO	NO	NO	NO	NO
	83~100%	Flash	ON	ON	ON	ON	ON	NO	NO	NO	NO	NO	NO
RUN Status		ON						Flash					

### 4 Connectors

Charge / Discharge connectors: to connect the positive pole (+) and negative pole (-) from the battery to the inverter via DC isolator.

RS485: Active communication portal between battery and inverter.

USB To RS232: to get dynamic monitoring data of the battery from upper computer.

Address: Reserved Address portal for multiple parallel connections.

## 5. Display function instruction

### 5.1 Reference of real figure

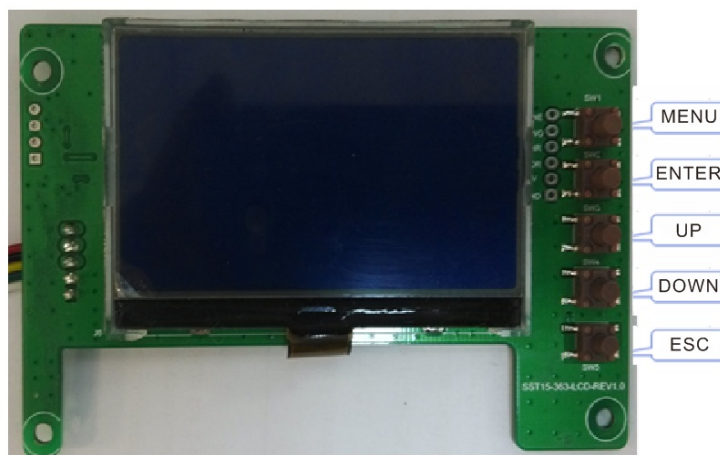

### 5.2 Display rendering



### 5.3 Functional Specifications

- Interface introduction
- Main menu page
- Electricity/dormancy activated, will show the welcome screen, press the MENU button to enter the main menu page. As shown in the figure below:



- Battery parameters collection page  
When the cursor“>>” is point to “Battery Parameters Acquisition”, press ENTER key will enter into the page of“ Battery Parameters Acquisition”, As shown in the

figure below:

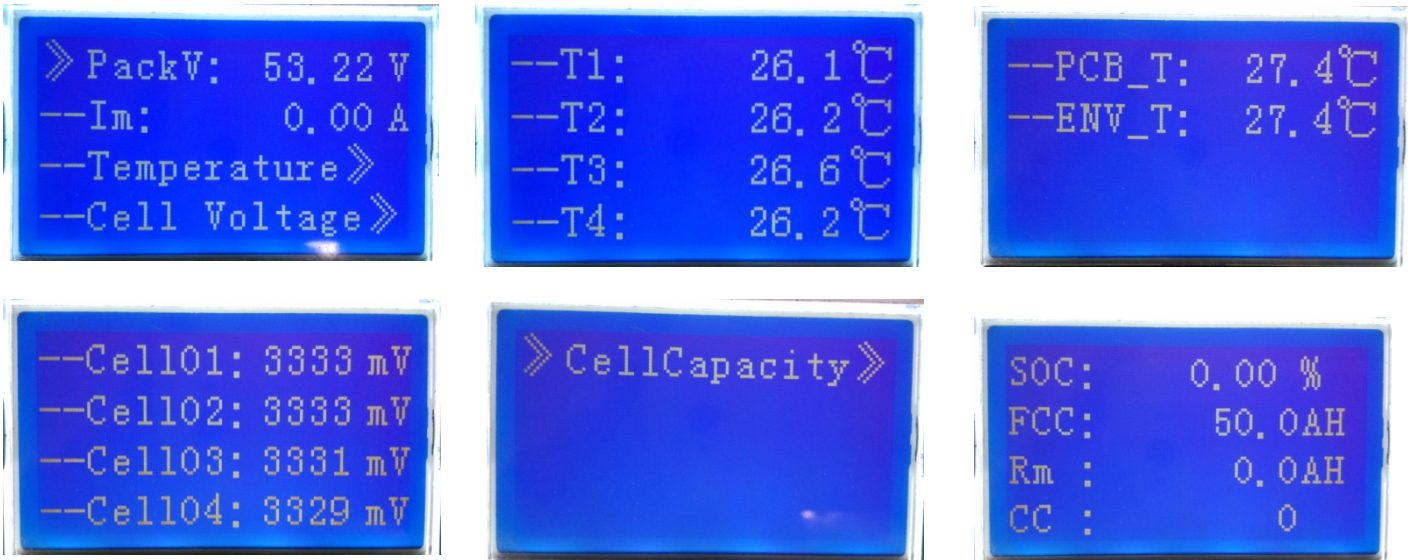

### ●Battery status page

When the cursor “»” is point to “ Battery Status”, press ENTER key will enter into the page of “Battery Status”, As shown in the figure below:

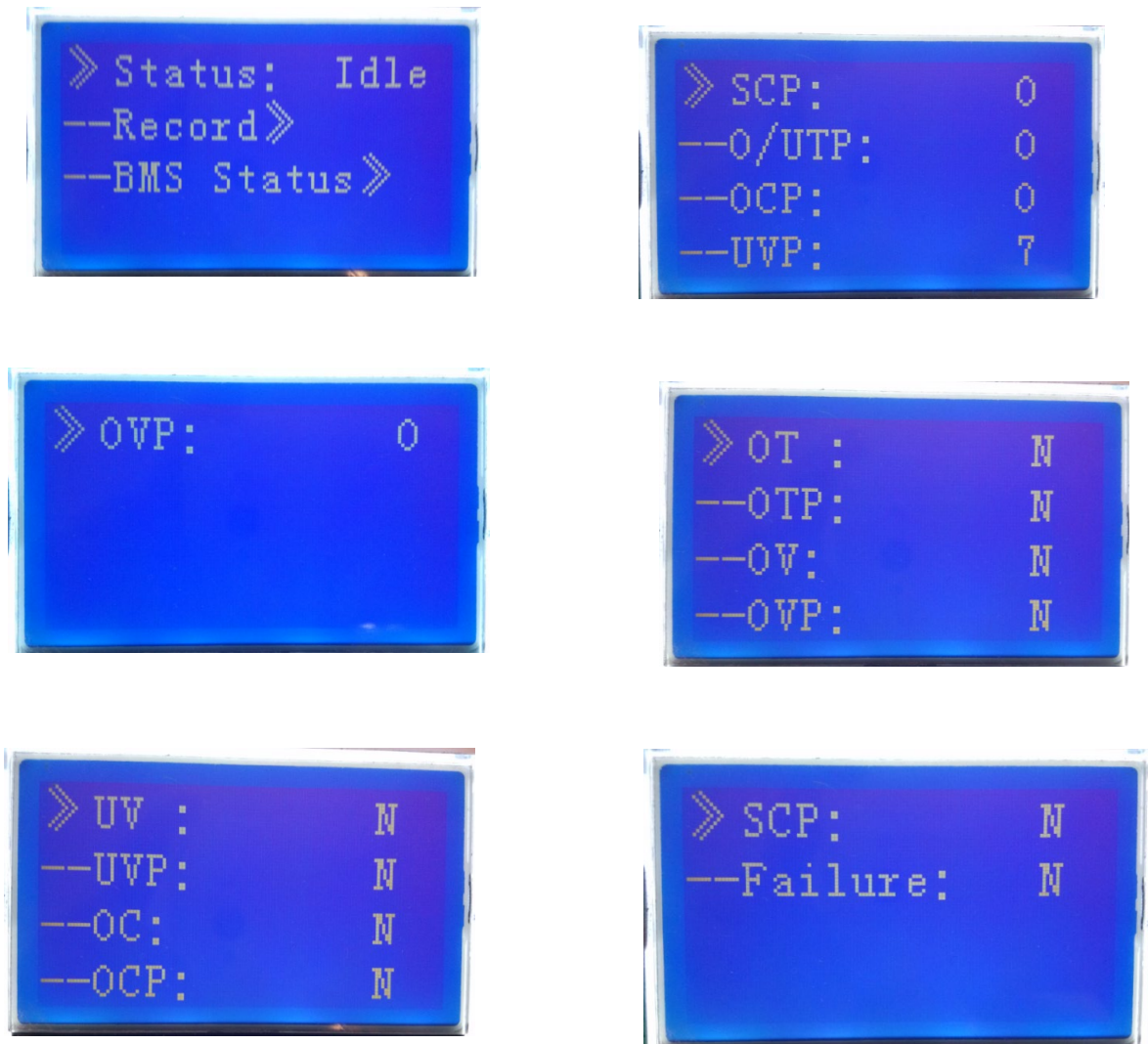

- Parameter Settings

Screen can not set parameters

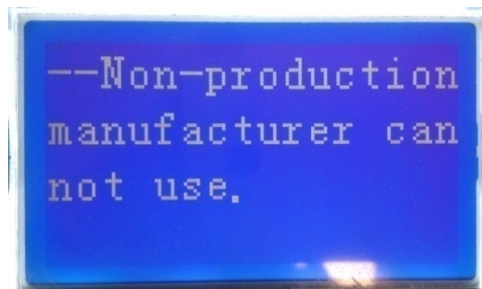

- System Settings Page

Baud Rate: 9600 do not set

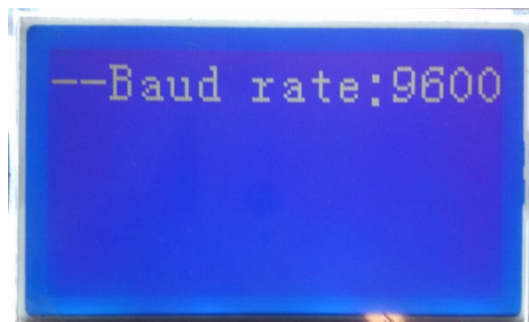

- Key description

- 1) SW1----NEMU, SW2----ENTER, SW3----UP, SW4----DOWN, SW5----ESC.
- 2) Each item is "»" or "--" as a beginning, among them "»" shows the current cursor position, press UP or DOWN key can move the cursor position; with "»" end of the project, the content of the said project has not shown, press ENTER key can enter the corresponding page.
- 3) Press ESC key can be returned at the next higher level directory; In any position, press NEMU key can return to the main menu page.
- 4) In a dormant state, press any key, can activate the screen.

- Dormancy/shutdown

Under normal operation condition, with no keystrokes 1 minutes later, system will enter a state of dormancy/shutdown.

Shutdown/dormancy state, press any key, screen can be activated.

## 5.4 Terminals of PV inverter

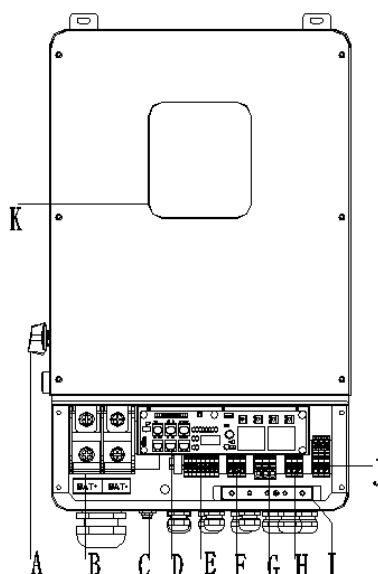

Object	Description
A	DC switch
B	BAT input
C	Wi-Fi
D	DRM/BMS/CT/DRY IO/CAN/USB upgrading
E	PV1~PV4 input
F	Generator
G	Grid
H	BACK-UP1 output
I	PE
J	BACK-UP2 output
K	LCD

## 6. Product Parameters:

8000VA 51.2V200AH Solar energy storage system	
<b>Battery Pack</b>	
Nominal voltage	51.2V
Rated capacity	400Ah
Rated reserved energy	20480Wh
Standard charging current	0.2C
Total charging cut-off voltage	57.6V
Cut-off voltage of charging monomer	3.65V



Standard discharging current	0.2C
Maximum continuous discharging current	200A
Cut-off voltage of discharging monomer	2.7V
Charging temperature range	0°C~55°C
Discharging temperature range	-20°C~65°C
<b>Inverter</b>	
<b>Technical Data</b>	<b>R8KLNA</b>
<b>PV Input Data</b>	
MAX.DC Input Power	12KW
NO.MPPT Tracker	4
MPPT Range	120 - 500V
MAX.DC Input Voltage	500V
MAX. Input Current	12A
<b>Battery Input Data</b>	
Nominal voltage (Vdc)	48V
MAX. Charging/Discharging Current	190A/190A
Battery Voltage Range	40-60V
Battery Type	Lithium and Lead Acid Battery
Charging Strategy for Li-Ion Battery	Self-adaption to BMS
<b>AC Output Data(On-Grid)</b>	
Nominal output power Output to Grid	8KVA
MAX. Apparent Power Output to Grid	8.8KVA
Output Voltage Range	110-120/220-240V split phase, 1Ø, 230 1 phase
Output Frequency	50/60Hz (45 to 54.9Hz / 55 to 65Hz)
Nominal AC Current Output to Grid	34.8A
Max.AC Current Output to Grid	38.3A
Max.AC Current From Grid	50A
Output Power Factor	0.8leading...0.8lagging
Out Put THDI	< 2%
<b>AC Output Data(Back-Up)</b>	
Nominal. Apparent Power Output	8KVA
MAX. Apparent Power Output	8.8KVA
Nominal Output Voltage L-N/L1-L2	120/240V
Nominal Output Frequency	60Hz
Output THDU	< 2%
<b>Efficiency</b>	
Europe Efficiency	>=97.8%
MAX. Battery to Load Efficiency	>=97.2%

## 7 .Installing the Battery Pack

### 7.1.Inventory of items

When you receive the goods, please check the packaging carefully. If any item is missing or the outer packaging is opened or the device itself is damaged, please contact the dealer immediately.

### 7.2. Installation Location

Make sure that the installation location meets the following conditions:

- The installation site must be suitable for the size and weight of the battery.
- There are no flammable or explosive materials in proximity
- The ambient temperature is within the range from 0°C to 45°C.  
There is minimal dust and dirt in the area.

## 8 Assembly

8.1. Place the cabinet on a level concrete floor and open the 2 cabinet doors at the back of the cabinet.

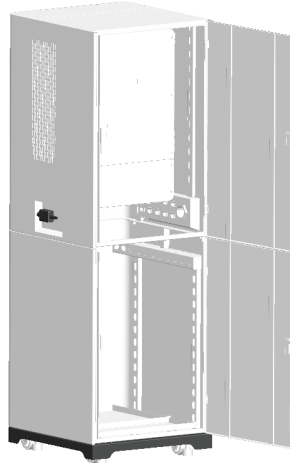

8.2. At least 2 operators are required to install the battery pack into the cabinet.

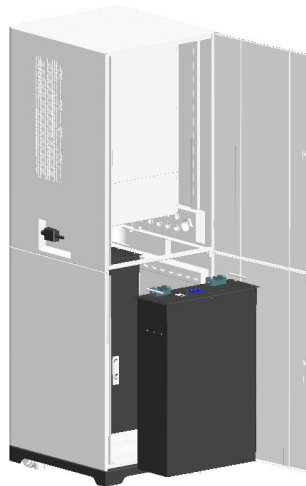

8.3. Fix the battery pack and wire, dial the dial switch to the location shown.

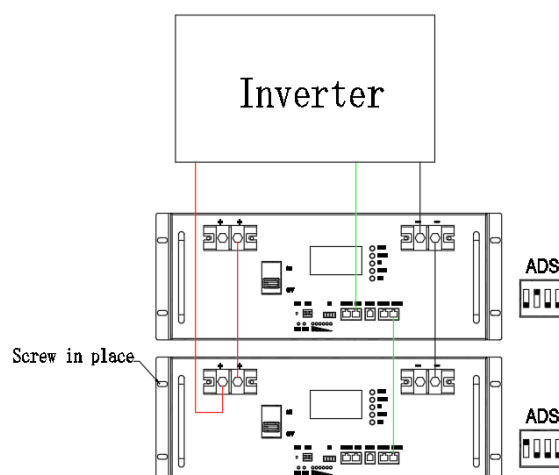

8.4. Remove the cover screws by Allen Wrench and remove the cover. Remove the waterproof cover by a flat blade screwdriver. Wiring box conduit plugs, Conduit plugs are provided for 1 inch conduit fittings. If used conduit fitting is not 1 inch, an appropriate conduit adaptor should be used.

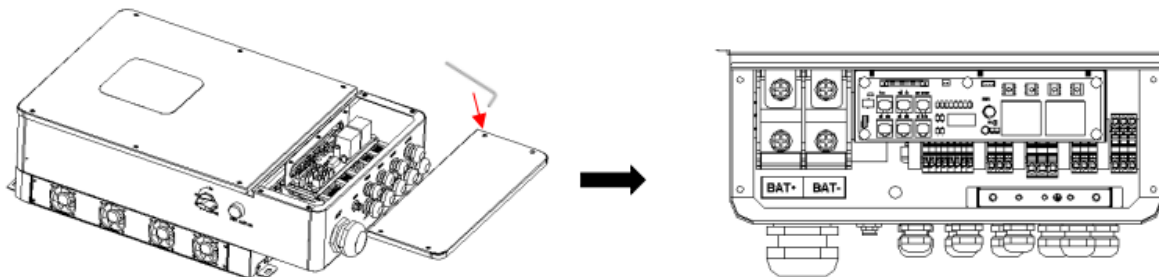

### Grid Connection (GEN connection)

#### Step1. Check the grid voltage.

- 1.1 Check the grid voltage and compare with the permissive voltage range (Please refer to technical data).
- 1.2 Disconnect the circuit board from all the phases and secure against re-connection.

#### Step2. Grid cables choose

Use the right pin terminal from the accessory box. Press the connectors on cable conductor core tightly.

Model	R5KLNA	R5KLNA	R7K6LNA	R8KLNA
Cable	12AWG		10AWG	

#### Step3. Choose the wire to connect with the cold-pressed terminal. (Remove 18mm of insulation from the end of wire.)

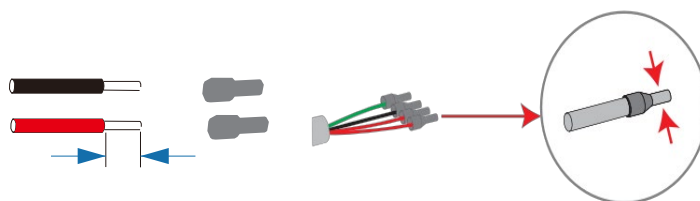

#### Step4. Cross the Grid cables although the grid port, Connect Grid cables to Grid terminals.

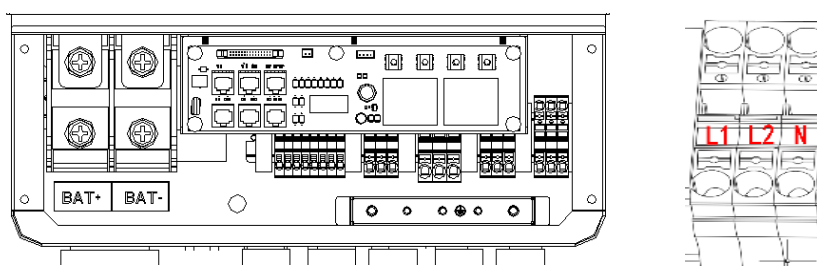

## 8.5 Back-up:Load1 and Load2 Connection

Inverter has On and Off grid function, the inverter will deliver output power through AC port when the grid is on, and it will deliver output power through back-up port when the the grid is off.

➤ **Auto & Manual**

BACK-UP function can be achieved automatically or manually according to user's wishes. BACK-UP function can only be triggered automatically.

➤ **Load1 port: important load.**

Load2 port: When the battery is not sufficient, the load on this interface will power down

1).For inverter, the standard PV installation typically consists of the connection of the inverter with both panels and batteries. In case of systems not connected to the batteries, the Back-Up function is strongly not advised to use. It shall not cover the standard warranty and be liable for any consequences arising from users not following this instruction.

2) Hybrid inverters are able to supply over load output at its "Back-Up". For details please refer to the technical parameters of inverter. And the inverter has self-protection dreading at high ambient temperature.

3) For complicated application, or Special load , please contact after-sales.

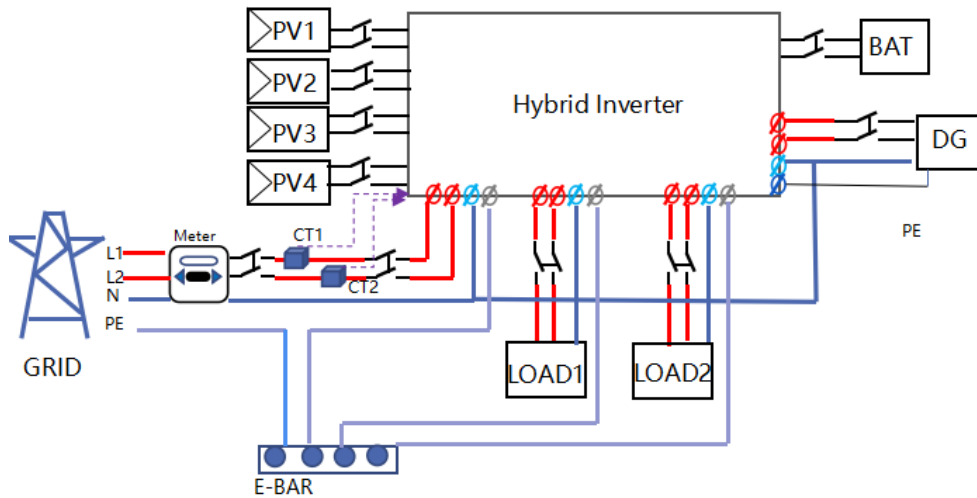

**Note!**



In case of discrepancies between wiring mode of local policy and the operation guide above, especially for the wiring of neutral line, grounding and RCD, please contact us before any operation!

➤ **Back-Up:Load1 and Load2 Connection:**

When using the off grid function, please add off grid AC breaker in off grid output cable to ensure safety.

Model	R5KLNA	R6KLN A	R7K6LN A	R8KLNA
-------	--------	------------	-------------	--------

Micro-breaker	32A	40A
---------------	-----	-----

**Note:** The absence of AC breaker on back-up side will lead to inverter damage if an electrical short circuit happens on back-up side.

**Step1.** Make BACK-UP wires.

Model	R5KLNA	R6KLNA	R7K6LNA	R8KLNA
Cable	12AWG		10AWG	

**Step2.** Connect the cables to the BACK-UP:Load1 and Load2 port of the inverter.

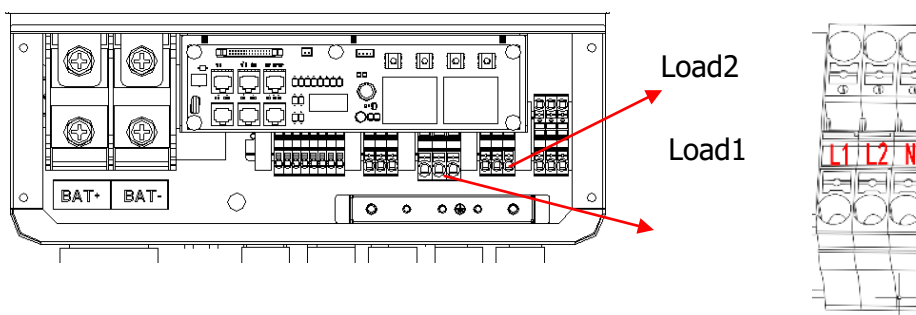

### ➤ Requirements for BACK-UP load

#### Warning!



Make sure the BACK-UP load power rating is within BACK-UP output rating, otherwise the inverter will shut down with an “over load” warning. When an “over load” is appeared, adjust the load power to make sure it is within the BACK-UP output power range, then turn the inverter back on. For the nonlinear load, please make sure the inrush power should be within the BACK-UP output power range.

### Battery connection diagram :

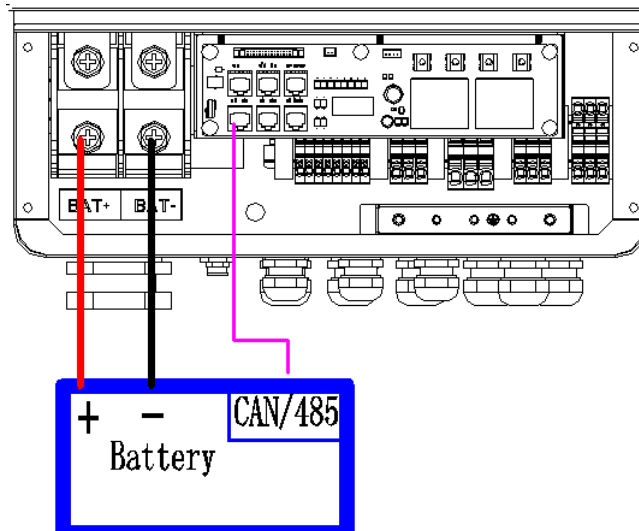

## Wi-Fi Connection (optional)

Inverter provides a Wi-Fi port which can collect data from inverter and transmit it to monitoring-website by Wi-Fi.

### 1) Diagram

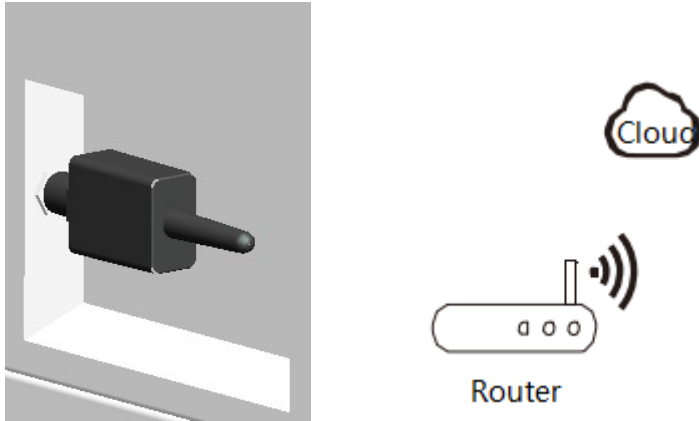

### 2)Wi-Fi Connection :

**Step1.** Plug Wi-Fi into “Wi-Fi” port at the bottom of the inverter.

**Step2.** Build the connection between the inverter and router.

**Step3.** Create a user account online.( Please check the Wi-Fi user manual for more details).

## 9. LCD Operation

### 9.1 Control Panel

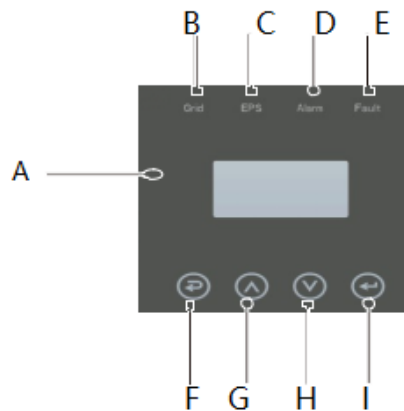

Object	Name	Description
A	LCD Screen	Display the information of the inverter.
B	Indicator LED	lit in green: The inverter is in grid mode. Off: The inverter is in not in grid mode.
C		lit in green: The inverter is in off-grid mode. Off: The inverter is in not in off-grid mode.

D		lit in Yellow: The inverter is in Warning . Off: The inverter has no Inverter Warning
E		lit in red: The inverter is in fault status. Off: The inverter has no errors.
F	Function Button	Esc: Return from current interface or function.
G		Up: Move cursor to upside or increase value.
H		Down: Move cursor to downside or decrease value.
I		Enter: Confirm the selection.

## 9.2 Instructions for LED Indicator

	Grid ( Green )	EPS ( Green )	Alarm (Yellow)	Fault (Red)
Initialization	off	off	off	off
Stand-by	off	off	off	off
Grid mode	on	off	off	off
Off-Grid	off	on	off	off
Bypass of mains	off	on	on	off
Fault	off	off	off	on

## 10. System use

### 10.1. Battery system boot

1. Reconfirm that the wiring is correct.
2. Press the RST key for 3 seconds, and the battery starts when the LED flashes from the RUN light to the minimum capacity indicator. Turn on battery pack output DC switch. Start the inverter.

## 11. Appendix: Tools

The following tools are required to install the battery pack.

