User Manual

Energy Storage System

YP-ESS10-8HVS1/2



About This Manual

The manual primarily encompasses product information, along with installation, operation, and maintenance guidelines.

It will refer to the device as the "ESS" unless otherwise specified.

- **Target Group**

This manual is intended for professional technicians who have responsibilities for the installation, operation, and maintenance of inverters, as well as users who need to check inverter parameters.

Installation Requirements:

The installation of the ESS should only be carried out by professional technicians who meet the following requirements

- Possess knowledge of electronics, electrical wiring, and mechanical expertise, and be familiar with electrical and mechanical schematics.
- Have received professional training related to the installation and commissioning of electrical equipment.
- Capable of promptly responding to hazards or emergencies that may arise during the installation and commissioning process.
- Familiar with local standards and relevant safety regulations pertaining to electrical systems.
- Thoroughly read this manual and understand the safety instructions associated with the operations.

- **Symbols**

This manual incorporates crucial safety instructions that are emphasized using specific symbols. These symbols are employed to ensure the safety of individuals and property during product usage or to assist in maximizing product performance efficiently.

It is essential to thoroughly comprehend the significance of the warning symbols to enhance your utilization of the manual.

Change History

Changes between document issues are cumulative, meaning that each subsequent document issue includes all the changes made in earlier issues.

V1.0 (2023-12-15)

This version is the first official release

Contents

目录

1 Safety Instructions	1
1.1 Unpacking and Inspection	1
1.2 Installation Safety	2
1.3 Electrical Connection Safety	2
1.4 Operation Safety	3
1.5 Maintenance Safety	3
1.6 Disposal Safety	4
2 Product Description	5
2.1 System Introduction	5
2.2 Product Introduction	6
2.2.1 Model Description	6
2.2.2 Appearance	6
2.2.3 Dimensions	6
2.2.4 Function interface description	8
2.3 Symbols on the Product	9
2.4 Hybrid Inverter	11
2.4.1 Inverter Comm. Interface	11
2.5 Battery	11
2.5.1 BMS Comm. Interface	11
2.5.2 SOC Indicator & Status Indicator Guides	11
2.6 PV Energy Storage System (PV&ESS)	15
2.6.1 PV Energy Storage System (PV&ESS)	15
2.6.2 Declaration For EPS Function	15
2.6.3 Energy Management	16
3 Function Description	18
3.1 Safety Function	18
3.1.1 Protection	18
3.1.2 Earth Fault Alarm	18
3.2 Energy Conversion and Management	18
3.2.1 Power Derating	18
3.2.2 Regular Operational Voltage Range	18
3.2.3 Regular Operational Frequency Range	19
3.2.4 Reactive Power Regulation	19
3.3 Communication and Configuration	19
3.4 Battery Management	19
3.4.1 Charge Management	20
3.4.2 Discharge Management	21
4 Unpacking and Storage	22
4.1 Unpacking and Inspection	22
4.2 Scope of Delivery	23

4.3 Product Storage	24
5 Mechanical Mounting	25
5.1 Safety during Mounting	25
5.2 Location Requirements	25
5.2.1 Environment Requirements	26
5.2.2 Carrier Requirements	26
5.2.3 Angle Requirements≥	26
5.2.4 Clearance Requirements	26
5.3 Installation Tools	27
5.4 Moving the ESS	27
5.5 Installing the ESS	28
6 Electrical Connection	31
6.1 Safety Instructions	31
6.2 The battery module connects to the inverter	32
6.2.1 Terminal Description	32
6.2.2 Connecting the AC Cable	33
6.3 DC Cable Connection	36
6.3.1 PV Input Configuration	37
6.3.2 Assembling the PV Connectors	38
6.3.3 Installing the PV Connector	40
6.4 WLAN- RS485 Connection	42
7 Commissioning	44
7.1 Inspection before Commissioning	44
7.2 Powering on the System	44
7.3 Download App	44
7.4 Registration	45
7.5 Create a Plant	45
7.6 Add a Logger	46
7.7 Network Configuration	46
7.8 Stick Logger Installation	48
7.9 Logger Status	48
7.9.1 Check Indicator light	48
7.10 Abnormal State Processing	49
8 System Decommissioning	51
8.1 Disconnecting the ESS	51
8.1.1 Disconnecting the ESS	51
8.1.2 Dismantling the ESS	51
8.1.3 Disposal of the ESS	51
8.2 Decommissioning the Battery	52
9 Appendix	53
9.1 Technical Data	53

1 Safety Instructions

Before using please read all instructions and cautionary markings on the unit and this manual. Store the manual where it can be accessed easily.

This manual is for qualified personnel. The tasks described in this manual may be performed by qualified personnel only.

Conventions used:**WARNING!**

Warnings identify conditions or practices that could result in personal injury;

CAUTION!

Caution identify conditions or practices that could result in damage to the unit or other equipment connected.

WARNING

- Avoid operating the product and cables (including but not limited to product movement, installation, operation, powering up, maintenance, and working at heights) under harsh weather conditions such as lightning, rain, snow, and level 6 or stronger wind.
- In case of fire, evacuate the building or the area where the product is located and immediately contact the fire department. Under no circumstances should re-entry into the burning area be attempted.

NOTICE

- Ensure that the product and terminals are securely fastened using the specified torque and appropriate tools. Failure to do so may result in product damage, and any resulting damage will not be covered by the warranty.
- Familiarize with the correct usage of tools to prevent injury to individuals or damage to the device.
- Maintain the device with sufficient knowledge of this manual and use proper tools.
 - ◆ The safety instructions provided in this manual are supplementary and may not encompass all precautions that should be followed. Always consider the actual on-site conditions when performing operations.
 - ◆ We will not be held liable for any damages caused by the violation of general safety operation requirements, general safety standards, or any safety instructions stated in this manual.
 - ◆ When installing, operating, and maintaining the product, comply with local laws and regulations. The safety precautions provided in this manual serve as supplements to local laws and regulations.

1.1 Unpacking and Inspection

WARNING

Before decommissioning the device, carefully inspect all safety signs, warning labels, and nameplates to ensure they are in place and clearly visible. These signs and labels should not be removed or covered at any time.

NOTICE

Upon receiving the product, conduct a thorough inspection to verify the condition of the device's appearance and structural components. Additionally, compare the contents of the packaging with the ordered product to ensure consistency. If there are problems with the above inspection items, do not install the device and contact your distributor first. If the problem persists, contact us for further assistance.

1.2 Installation Safety

DANGER

- Before installation, ensure that there is no electrical connection present.
- Before drilling, take precautions to avoid any water or electrical wiring in the wall.

CAUTION

Improper installation can result in personal injury!

- If the product supports hoisting for transportation using hoisting tools, it is strictly prohibited for anyone to remain under the product.
- When moving the product, take into account its weight and maintain balance to prevent tilting or falling.

NOTICE

Prior to operating the product, it is crucial to inspect and verify that the tools to be used have undergone regular maintenance.

1.3 Electrical Connection Safety

DANGER

Before making electrical connections, it is essential to ensure that the ESS is undamaged to prevent potential dangers!

Before electrical connections, confirm that all switches connected to the ESS are set to the "OFF" position to avoid the risk of electric shock!

DANGER

The PV string generates a lethal high voltage when exposed to sunlight. Please observe the following safety precautions during electrical connections.

- Operators must wear appropriate personal protective equipment.
- Use a measuring instrument to verify that cables are voltage-free before touching DC cables.
- Adhere to all safety instructions provided in relevant documents concerning PV strings.

DANGER

There is a risk of high voltage inside the ESS that can be life-threatening. Please take note of the following precautions!

- Use specialized insulation tools during cable connections.
- Follow and strictly adhere to the warning labels on the product and the safety instructions.

- Respect all safety instructions stated in this manual and other relevant documents.

DANGER

Batteries deliver electrical power and can cause burns or fire hazards when short-circuited or incorrectly installed. Lethal voltages are present at the battery terminals and cables connected to the ESS. Avoid touching the cables and terminals to prevent severe injuries or death.

WARNING

- Damage to the product resulting from incorrect wiring is not covered by the warranty.
- Electrical connections should be performed by professionals.
- All cables used in the PV generation system must be securely attached, properly insulated, and adequately sized.

-

WARNING

Ensure to check the positive and negative polarity of the PV strings and connect the PV connectors to the corresponding terminals only after confirming the correct polarity. During the installation and operation of the ESS, prevent the positive or negative poles of PV strings from short-circuiting to the ground to avoid AC or DC short-circuits that could lead to equipment damage. Such damage is not covered by the warranty.

NOTICE

Comply with the safety instructions regarding PV strings and adhere to the regulations applicable to the local grid.

1.4 Operation Safety

DANGER

- Do not touch the enclosure of the ESS while it is running.
 - It is strictly prohibited to plug or unplug any connectors on the ESS while it is running.
 - Avoid contact with any terminals of the ESS while it is running to prevent electric shock.
 - Do not disassemble any parts of the ESS while it is running, as it may result in electric shock.
 - Refrain from touching any hot parts of the ESS, such as the heat sink, while it is running to avoid burns.
 - If the ESS is equipped with a DC switch, do not operate it while it is running to prevent device damage or personal injury.
-

1.5 Maintenance Safety

DANGER

There is a risk of ESS damage or personal injury resulting from incorrect service procedures!

- Prior to performing any service work, disconnect the grid-side AC circuit breaker and check the status of the ESS. If the ESS indicator is off, wait until nighttime before disconnecting the DC switch. If the ESS indicator is on, you can directly disconnect the DC switch.
- After the ESS has been powered off for at least 10 minutes, use a professional instrument to measure the voltage and current. Only when there is no voltage or current detected, and operators are wearing

proper protective equipment, can they proceed with operating and maintaining the ESS.

- Even if the ESS is shut down, it may still be hot and cause burns. Wear protective gloves before operating the ESS after it cools down.

DANGER

Touching the power grid or the contact points and terminals on the ESS connected to the power grid can result in electric shock!

- The power grid side may have voltage. Always use a standard voltmeter to ensure there is no voltage before touching.

CAUTION

To prevent misuse or accidents caused by unauthorized personnel, prominently display warning signs or designate safety warning areas around the product.

NOTICE

To avoid the risk of electric shock, refrain from performing any maintenance operations beyond those described in this manual. If necessary, contact your distributor first. If the issue persists, contact us for maintenance. Failure to do so may result in losses that are not covered by the warranty.

1.6 Disposal Safety

WARNING

Please dispose of the product in accordance with the applicable local regulations and standards to prevent property losses or injuries

2 Product Description

2.1 System Introduction

This energy storage system can provide power to connected loads by utilizing PV power, utility power and battery power and store surplus energy generated from PV solar modules for use when needed. When the sun has set, energy demand is high, or there is a black-out, you can use the energy stored in this system to meet your energy needs at no extra cost. In addition, this energy storage system helps you pursue the goal of energy self-consumption and ultimately energy-independence.

Depending on different power situations, this energy storage system is designed to generate continuous power from PV solar modules (solar panels), battery, and the utility. When MPP input voltage of PV modules is within acceptable range (see specification for the details), this energy storage system is able to generate power to feed the grid (utility) and charge. This energy storage system is only compatible with PV module types of single crystalline and poly crystalline. Do not connect any PV array types other than these two types of PV modules to the energy storage system. Do not connect the positive or negative terminal of the solar panel to the ground. See Figure 1 for a simple diagram of a typical energy storage system.

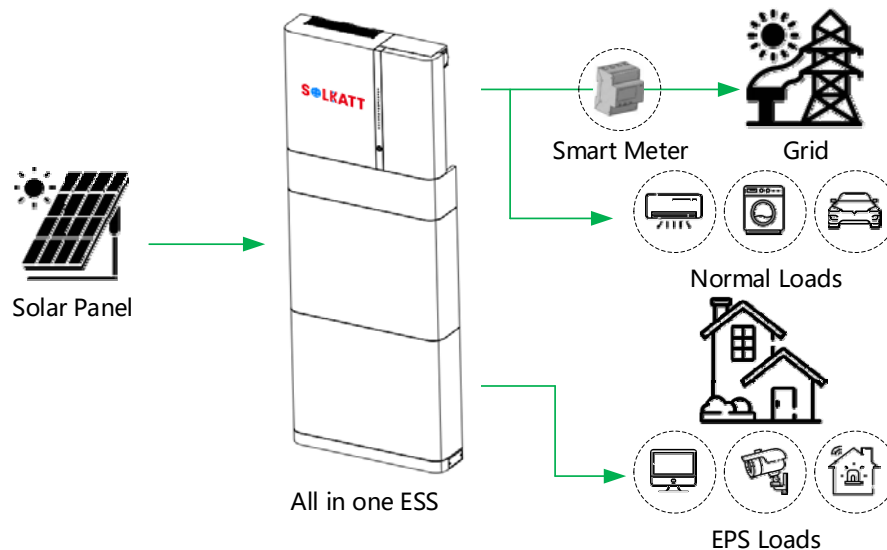

Figure 2-1 Energy storage System Overview

WARNING

- Operate the ESS only with PV strings having class II protection (IEC 61730, application class A). Avoid grounding the positive or negative poles of the PV strings to prevent damage to the ESS.
- Warranty does not cover damages caused by faulty or damaged PV installations.
- Only use the ESS as described in this document; any other use is not permitted.
- During installation and operation, ensure that the positive and negative polarities of PV strings and batteries do not short-circuit to the ground to avoid equipment damage. Warranty does not cover damage resulting from such short-circuits.
- Avoid short-circuiting the EPS port during operation to prevent severe damage to the ESS or power distribution system. Such damage is not covered by the warranty.

NOTICE

- In a TT utility grid, ensure that the N line voltage to ground is 30V or below.
- For off-grid applications, the utility grid must be a TN system.
- The system is not suitable for powering life-sustaining medical devices, and it does not guarantee EPS power in all situations.
- The ESS is designed for the specific scenarios described in this manual.

2.2 Product Introduction

2.2.1 Model Description

The model description is follows (take ESS10-8.64HV2 as an example):

ESS6: All-in-one Energy Storage System, And maximum Power level is 10kW

8.64: 8.64kWh per Battery PACK

HV: High voltage battery

2: include two battery PACK or (8.64*2) kWh Battery

2.2.2 Appearance

The image shown here is for reference only. The actual product received may differ.

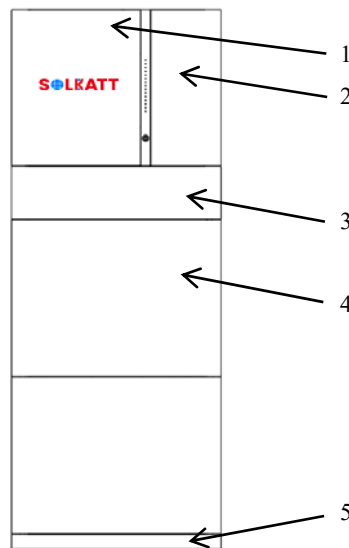

figure 2-2 ESS Appearance

No.	Name	Description
1	Hybrid Inverter	Indicates the current operating state of the inverter.
2	Smart Meter	Electricity meter and air switch area
3	Electrical connection area	Includes DC terminals, AC terminals, battery terminals, communication terminals and additional grounding terminal.
4	Battery	A Li-ion battery.
5	Base	Battery bottom support

2.2.3 Dimensions

The following table shows the dimensions of the ESS.

Model	W(mm)	H(mm)	D(mm)
ESS10-8.64HV1	770	1415	208
ESS10-17.28HV2	770	1998	208

ESS10-8.64HV1

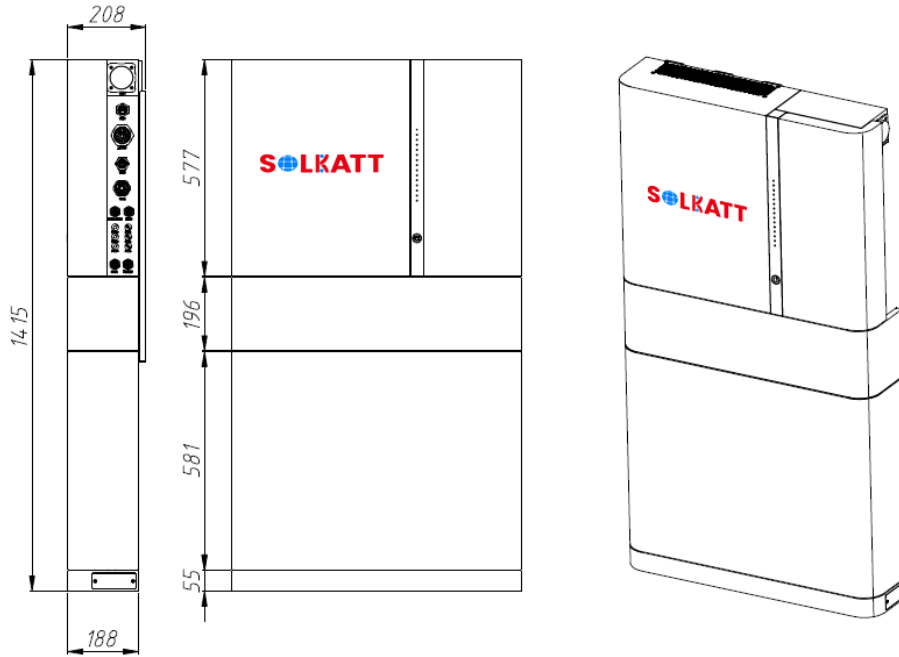

ESS10-17.28HV2

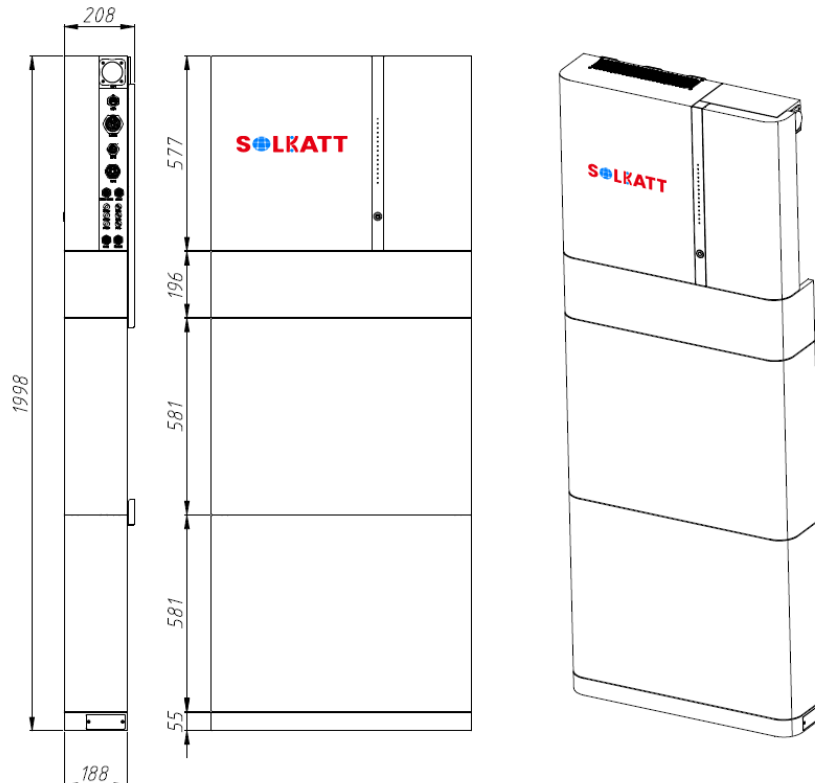

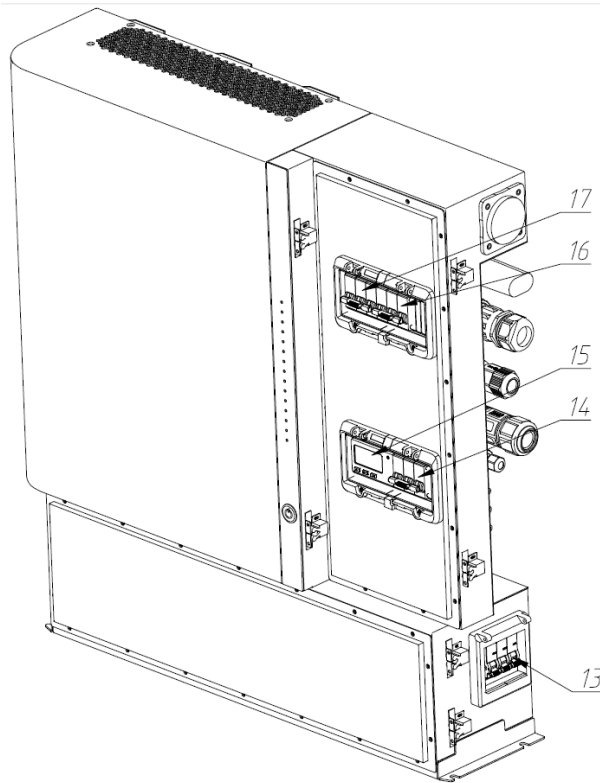
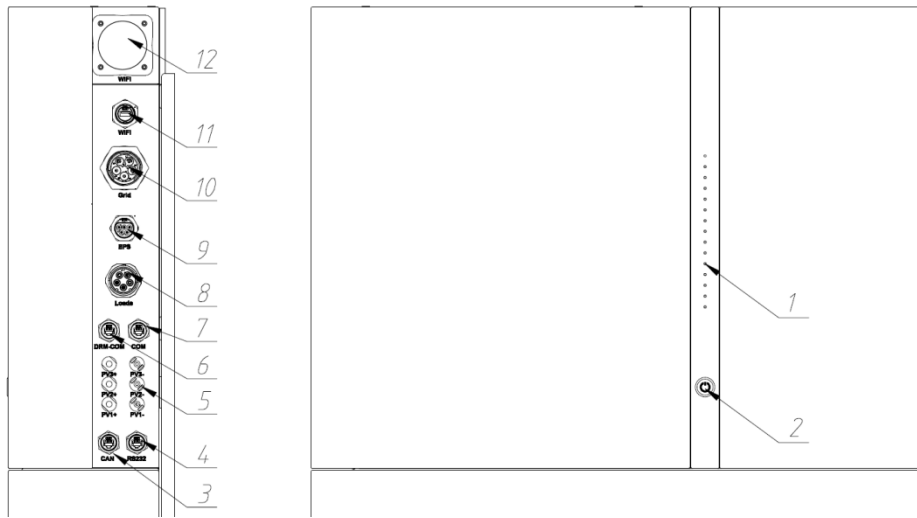

2.2.4 Function interface description



No.	Description	Silk-screen	Remark
1	LED indicate	CAPACITY	Capacity indicator
2	E-switch	ON/OFF	
3	CAN bus Port	CAN	CAN bus and inverter connection port
4	RS485A Port	RS485A	RS485A and inverter connection port
5	PV1+, PV1-, PV2+, PV2-, PV3+, PV3-	MC4 terminals for PV input. The terminal number depends on	DVC-C

6	DRM-COM	Communication connection for DRM	DVC-A
7	COM	Test Port	DVC-A
8	Loads	AC terminal for connection to the utility grid	DVC-C
9	EPS	AC terminal reserved for Backup loads	DVC-C
10	GRID terminal	AC terminal for connection to the utility grid	DVC-C
11	WI-FI-inverter	Communication accessory port to be connected to SOLARMAN Smart communication module.	DVC-A
12	WI-FI-master control	Connect to the communication module of the main control box	DVC-A
13	DC air switch	DC switch	
14	Loads air switch	Loads switch	
15	electricity meter		
16	EPS air switch	EPS switch	
17	GRID air switch	GRID switch	

2.3 Symbols on the Product

Symbol	Explanation
PV	Parameters on the PV side.
BAT	Parameters on the Battery side.
AC-Grid	Parameters on the AC on-grid side.
AC-EPS	Parameters on the AC EPS side.
	<p>Danger to life due to high voltages!</p> <p>Do not touch live parts for 10 minutes after disconnection from the power sources.</p> <p>Only qualified personnel can open and maintain the ESS.</p>
	Read the user manual before maintenance!



There is a deadly high pressure danger!
Only professional and qualified personnel are
allowed to install and operate!

RoHS

RoHS mark of conformity.



Regulatory compliance mark.

**UK
CA**

UKCA mark of conformity.



CE mark of conformity.



Do not dispose of the ESS together with household waste.



TÜV mark of conformity.

2.4 Hybrid Inverter

2.4.1 Inverter Comm. Interface

If there is any change in the pin position of the communication line, the customer shall be notified in writing or provided with supporting communication wire.

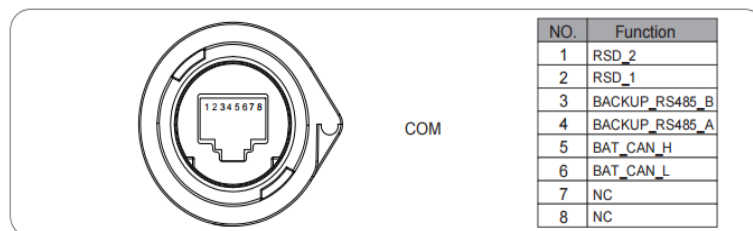
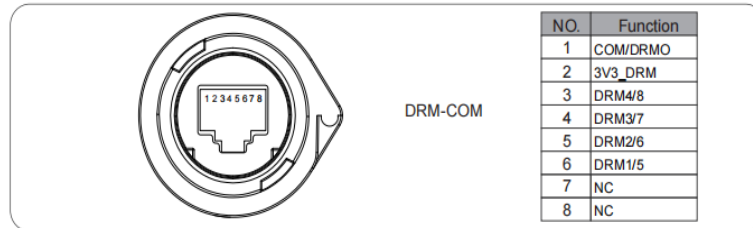

2.5 Battery

2.5.1 BMS Comm. Interface

If there is any change in the pin position of the communication line, the customer shall be notified in writing or provided with supporting communication wire.

Communication with	RS485B interface	RS485-8P8C			
		RJ45 Pin	Definition Description	RJ45 Pin	Definition Description
host computer		1	RS485B_B	5	NC
		2	RS485B_A	6	NC
		3	NC	7	RS485B_A
		4	NC	8	RS485B_B
External communication	CAN And RS485A interface	CAN-8P8C			
		RJ45 Pin	Definition Description	RJ45 Pin	Definition Description
		1	RS485A_B	5	CAN_L
		2	RS485A_A	6	NC
		3	NC	7	RS485A_A
		4	CAN_H	8	RS485A_B

2.5.2 SOC Indicator & Status Indicator Guides

1 Start self-test: Green LED runs from low to high, and then enters standby after completion , such as from lamp 1 to lamp 15, after completion, turn on the charge and discharge function.

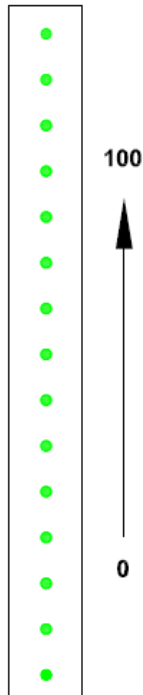

2 It is always on during normal operation (displayed according to the set color, except for red), as shown in the figure below, the lamp shade is displayed in green (when set to green)



3 Fault, long red light bar (red light flashes 1S /1 times when alarming)



4 Charging, running in cycle

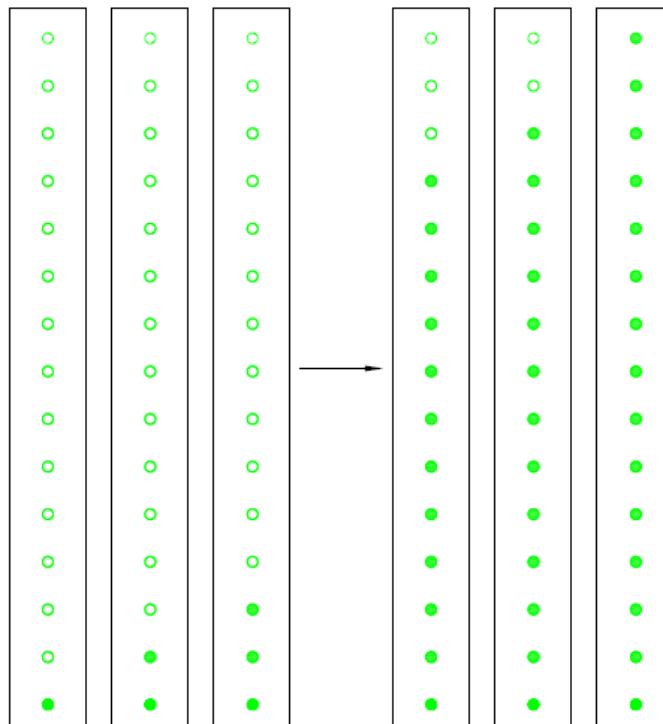

5 Discharging, decreasing according to energy.

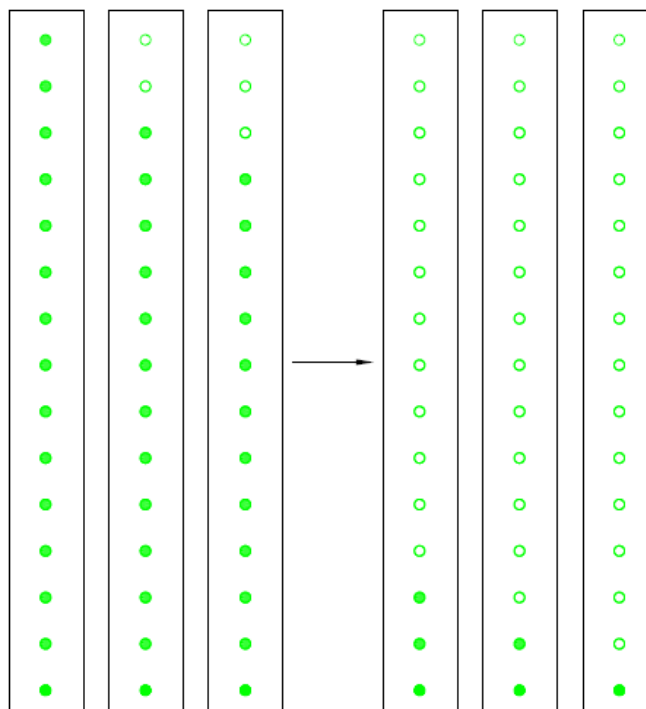

2.6 PV Energy Storage System (PV&ESS)

2.6.1 PV Energy Storage System (PV&ESS)

The following figure shows ESS application in a PV energy storage system.

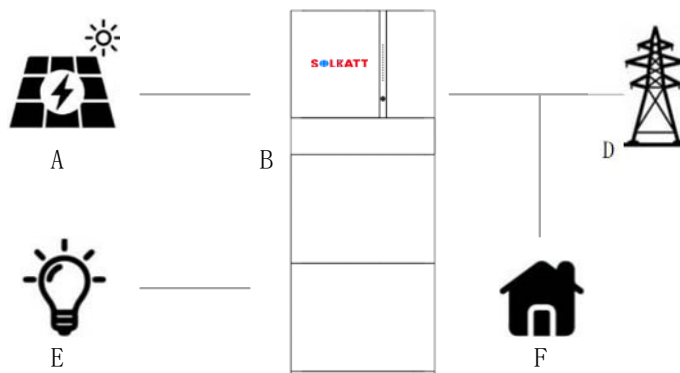

figure 2-5 PV Energy Storage System

Item	Description	Note
A	PV strings	Compatible with monocrystalline silicon, polycrystalline silicon, and thin-film modules without grounding.
B	All in one ESS	ESS10-17.28HV2/ESS10-8.64HV1
C	Metering device	Inside the battery inverter, it is visible when the cover is opened
D	Utility grid	TT, TN-C, TN-S, TN-C-S.
E	EPS Loads	Loads, connected to EPS port, which need uninterrupted power supply.
F	Normal Loads	Some unimportant loads

2.6.2 Declaration For EPS Function

DANGER

This product is not intended for supplying power to life-sustaining medical devices. Power outages may pose a risk to life when relying on this product for such purposes.

The following statements outline our general policies concerning the ESS described in this document:

1 For the ESS, the electrical installation typically involves connecting the inverter to PV modules. In EPS mode, if there is no available power from batteries or PV modules, the EPS power supply will be automatically terminated. We bears no responsibility for any consequences resulting from failure to comply with this instruction.

2 Normally, the switching time for activating the EPS mode is less than 10 ms. However, certain external factors may cause the system to fail in EPS mode. Therefore, users must be aware of the following conditions and adhere to the instructions:

- Do not connect loads that require a stable energy supply for reliable operation.
- Do not connect loads whose total capacity exceeds the maximum EPS capacity.
- Do not connect loads that may cause high start-up current surges, such as air conditioners, high-power pumps, vacuum cleaners, and hair dryers.

- Battery current may be limited due to factors including temperature and weather conditions.

Declaration For EPS Overload Protection

In the event of overload protection, the hybrid inverter will automatically restart. If overload protection is repeatedly triggered, the restart time may increase (up to a maximum of 10 minutes). To avoid this, reduce the power of the EPS load to remain within the specified limits or remove loads that may cause high start-up current surges.

2.6.3 Energy Management

NOTICE

- The battery discharges to provide energy to loads. If the battery is empty or there is not enough power from the battery system, the grid shall supply power to EPS loads and normal loads.
- When the grid is available, the hybrid inverter activates the bypass function. This allows the EPS loads to be directly connected to the grid via the integrated bypass switch in the inverter.
- If the Smart Energy Meter is either not present or experiencing abnormalities, the ESS will continue to operate normally. However, the battery will only be allowed to charge and not discharge. In this scenario, the feed-in power setting becomes ineffective, and the DO function for optimized mode will be disabled.

Energy Management during Daytime

The energy management system (EMS) defaults to self-consumption mode. The following scenarios illustrate the energy management process:

- Scenario 1: PV power generation > Load power consumption
 - First, PV power is prioritized for the EPS loads first, followed by normal loads and then the battery.
 - If the battery is fully charged, any excess power will be fed back to the grid. The feed-in power will not exceed the feed-in limitation value set in the initial settings.
- Scenario 2: PV power generation < Load power consumption
 - In this case, the battery will discharge to compensate for the energy shortfall.
 - If the combined power from the PV and battery is still insufficient to meet the load power demand, the inverter will draw power from the mains (grid) to make up for the deficit.

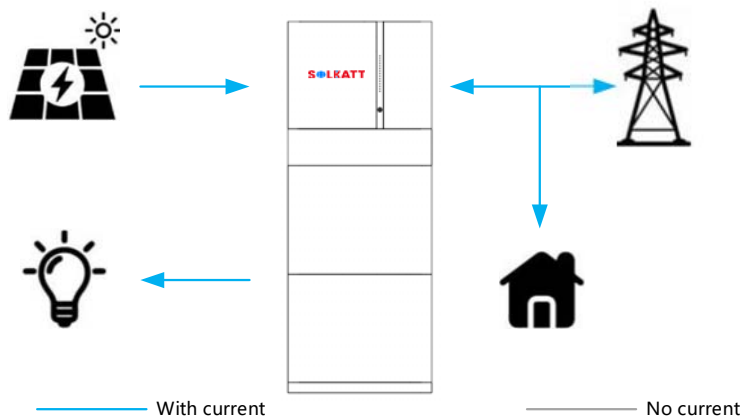

figure 2-6 EMS During Daytime

Energy Management during Night

During the nighttime period, energy management operates as follows:

- Battery Discharge: With available energy, the battery will discharge to provide power for the loads. It acts as the primary source of power during this time.

- **Grid Power Supply:** If the discharge power of the battery is insufficient to meet the load requirements, the grid will automatically supply power to the loads. This ensures a continuous and uninterrupted power supply, even if the battery capacity is depleted or unable to sustain the load demand.

By combining the discharge capability of the battery and the EPS power from the grid, the system ensures reliable and continuous power supply during nighttime operations.

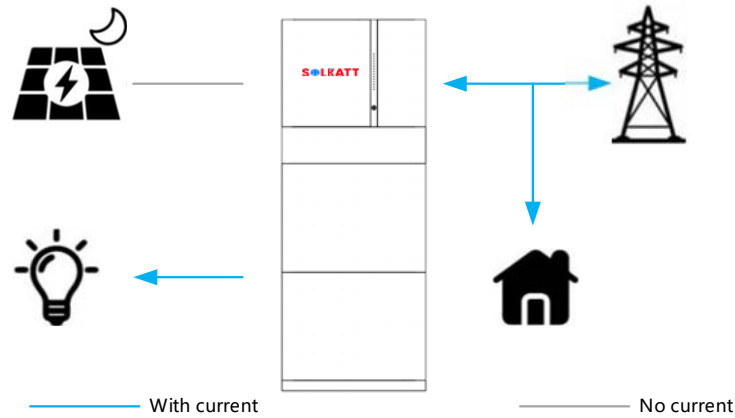

figure 2-7 EMS During Night

During night, when the battery is empty, it will enter into standby mode. In this case, the grid will supply all power for loads.

3 Function Description

3.1 Safety Function

3.1.1 Protection

Several protective functions are integrated in the ESS, including short circuit protection, grounding insulation resistance surveillance, residual current protection, anti-islanding protection, DC over-voltage / over-current protection, etc.

3.1.2 Earth Fault Alarm

The device is equipped with a grounding fault alarm system. In the event of inadequate or nonexistent grounding on the AC side, an audible alarm will sound and the LED indicator will illuminate in red.

3.2 Energy Conversion and Management

The ESS efficiently transforms the DC power derived from either the PV array or the battery into AC power that meets the specifications of the grid. Additionally, it facilitates the transfer of DC power from the PV panel to the battery.

Incorporating a bidirectional converter, the ESS has the capability to both charge and discharge the battery, ensuring optimal utilization of energy.

To maximize the power output from PV strings that may have varying orientations, tilts, or module structures, the ESS employs multiple string Maximum Power Point (MPP) trackers. These trackers enable the ESS to extract the maximum available power from each PV string, thereby enhancing overall system efficiency.

3.2.1 Power Derating

Power derating is implemented as a protective measure to safeguard the ESS against potential overload or faults. Moreover, the derating function can be activated in accordance with the requirements specified by the utility grid. Various situations that may necessitate ESS power derating include:

- Over-temperature conditions, which encompass both ambient temperature and module temperature.
- High input voltage levels.
- Grid under-voltage occurrences.
- Grid over-frequency events.
- Power factor deviations from the rated values.
- High altitude environments.

For seamless integration with demand response capabilities, the ESS is equipped with a terminal block designed to connect to a demand response enabling device (DRED). This DRED facilitates the activation of demand response modes (DRMs). When triggered, the ESS promptly detects and initiates a response to all supported demand response commands within a swift 2-second timeframe.

3.2.2 Regular Operational Voltage Range

The ESS are designed to operate effectively within the allowable voltage range for a specified observation time. The specific conditions for setting these voltage range parameters depend on whether the connection is

for a normal operational start-up or an automatic re-connection following a tripping event triggered by interface protection.

If the voltage level deviates from the defined operational levels, the ESS will disconnect from the grid within the protection time frame. In the event of a short-lived disturbance that lasts for a duration shorter than the required protection time, the ESS can automatically reconnect to the grid once the voltage level returns to normal operating levels after the disturbance subsides.

3.2.3 Regular Operational Frequency Range

The ESS is designed to operate within its specified frequency range for a minimum observation time. The specific conditions for setting these frequency range parameters depend on whether the connection is for a normal operational start-up or an automatic re-connection following a tripping event triggered by interface protection..

If the frequency level falls outside the defined operational range, the ESS will disconnect from the grid. In the case of a temporary disturbance that lasts for a duration shorter than the required protection time, the ESS can automatically reconnect to the grid once the frequency level returns to normal operating levels after the disturbance subsides.

3.2.4 Reactive Power Regulation

The ESS offers reactive power regulation modes to provide grid support. The specific reactive power regulation mode can be configured and adjusted through the SOLARMAN Smart App.

3.3 Communication and Configuration

The ESS offers RS485, Ethernet, WLAN, and CAN ports for device and system monitoring. These ports allow configuration of parameters for optimal operation. ESS information is accessible through the SOLARMAN Smart App.

The import power refers to the total power obtained from the grid, which encompasses the power used to charge the battery from the grid through the ESS, the power consumed by local loads, and the power supplied to loads connected to the ESS's EPS port from the grid. To comply with local regulations, it is necessary to calculate the maximum allowable system power based on the wire size and circuit breaker required for the selected model. This value can be configured as the Import Power Limit, which can be conveniently adjusted using the SOLARMAN Smart App.

3.4 Battery Management

Li-ion battery are compatible with the PV ESS, further battery models will be made compatible in the future. To optimize battery lifespan, the ESS will conduct battery charging, discharging, and maintenance activities based on the battery status information received from the Battery Management System (BMS).

NOTICE

The suggested parameters provided in this section are subject to updates and revisions as a result of product

advancements. For the most up-to-date information, please consult the manual provided by the battery manufacturer.

State Definition

To prevent excessive charging or discharging of the battery, three battery statuses have been defined based on different voltage ranges. Please refer to the table below for more details.

SOC definition	Port Voltage / SOC		
	Empty	Normal	Full
By default	SOC < 10%	10%...95%	SOC = 100%

NOTICE

If the battery has remained unused or has not been fully charged for an extended period of time, it is advisable to manually perform a full charge every 15 days. This practice helps to maintain the battery's lifespan and optimal performance.

3.4.1 Charge Management

EPS Charge Management

The purpose of the emergency charge management function is to safeguard the battery against damage resulting from prolonged excessive discharge. During emergency charging, the ESS is unable to respond to discharge commands. The table below outlines the emergency charge conditions for different types of Li-ion batteries.

table 3-1: EPS Charge Management for Li-ion Battery

BMS LED Status	Conditions
Trigger	<p>Either of the following conditions is met:</p> <ul style="list-style-type: none"> - A battery under-voltage warning is triggered. - An emergency charge command is reported to the inverter.
Finish	<p>All the following conditions are met:</p> <ul style="list-style-type: none"> - The battery under-voltage warning is cleared. - The emergency charge command reported to the inverter is cleared.

table 3-2 Default SOC Conditions for Li-ion Battery EPS Charge

SOC definition	Trigger SOC	Finishing SOC
By default	SOC = 0%	SOC > 10%

Normal Charge Management

During normal operation, when the battery voltage is within the acceptable range, the inverter is capable of charging the battery if the PV power exceeds the load power. It ensures that the battery is not overcharged.

The maximum charge current is restricted to the lower value between the following:

- The maximum charge current specified by the inverter (100A).
- The maximum/recommended charge current recommended by the battery manufacturer.

As a result, the battery charge power may not reach the nominal power level.

3.4.2 Discharge Management

Discharge Management

Discharge management is implemented to prevent deep discharging of the battery, ensuring its protection.

The maximum allowable discharge current is limited to the lower value between the following:

- The maximum discharge current specified by the inverter (100A).
- The maximum/recommended discharge current recommended by the battery manufacturer.

As a result, the battery discharge power may not reach the nominal power level.

4 Unpacking and Storage

4.1 Unpacking and Inspection

The product undergoes comprehensive testing and rigorous inspection prior to shipment. However, there is still a possibility of damage occurring during transit. Therefore, it is essential to conduct a thorough inspection upon receiving the product. Please follow these steps:

- Examine the packaging case for any visible signs of damage.
- Verify the contents of the delivery to ensure completeness, referring to the packing list.
- After unpacking, carefully inspect the inner contents for any signs of damage.

If any damage or incompleteness is detected, promptly contact us or the transport company. It is advisable to provide photographs of the damage to facilitate the resolution process. It is important not to discard the original packaging case. When decommissioning the product, it is recommended to store it in the original packaging case for safekeeping.











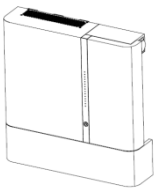
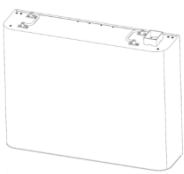

NOTICE

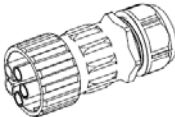
Upon receiving the product, it is important to conduct a thorough inspection to ensure its integrity and avoid any potential damage. Please follow these steps:

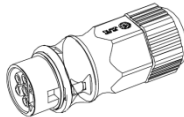
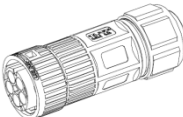
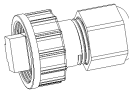
- Examine the appearance and structural parts of the device for any signs of damage.
- Verify that the contents of the package match the items listed on the packing list. Ensure that you have received the correct product.
- If any issues or discrepancies are found during the inspection, refrain from installing the device and immediately contact your distributor for assistance. If the problem persists or your distributor is unable to resolve the issue, promptly reach out to us for further support.

When unpacking the product, exercise caution to avoid causing any damage, especially if using tools. Take care to handle the product with care and ensure that no unintentional harm is inflicted upon it.

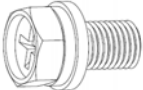
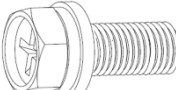
4.2 Scope of Delivery

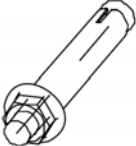
				
A	B	C	D	E
				
F	G	H	I	J
				
K	L	M	N	O
				
P	Q	R		

Item	Name	Quantity(ESS10-8.64HV1)	Quantity(ESS10-17.28HV2)
A	Hybrid Inverter+High pressure box	1	1
B	Battery Module	1	2
C	Base	1	1
D	Battery bracket	0	1
E	Top Bracket	1	1
F	LOAD Connector	1	1
G	LOAD Connector Terminals	5	5
H	AC Connector	1	1
I	GRID Connector	1	1
J	Communication Connector	2	2
K	WIFI Stick	1	1
L	PV connectors	3+3	3+3
M	Manual	1	1
N	Mounting screws M6	4	4
O	Mounting screws M10	4	4
P	M4 Flat-head screws	4	8
Q	Fixed Part	2	6
R	M6 expansion bolt	7	10

4.3 Product Storage

To ensure the proper storage of the ESS Product when it is not immediately installed, please adhere to the following guidelines:

- Store the ESS Product in its original packing case, ensuring the desiccant is kept inside.
- Maintain a storage temperature between -30°C and $+70^{\circ}\text{C}$ at all times.
- Maintain a storage relative humidity between 0% and 95%, ensuring it is non-condensing.
- If stacking storage is necessary, ensure that the number of stacking layers does not exceed the limit indicated on the outer side of the packing case.
- Keep the packing case upright during storage.
- If the ESS Product needs to be transported again, ensure it is properly packed before loading and transporting.
- Avoid storing the product in areas susceptible to direct sunlight, rain, or strong electric fields.
- Avoid placing the product near items that may affect or damage it.
- Store the product in a clean and dry location to prevent dust and water vapor from causing erosion.
- Avoid storing the product in areas with corrosive substances or at risk of being accessed by rodents and insects.
- Conduct periodic inspections, at least once every six months.
- If any signs of insect or rodent bites are detected, promptly replace the packaging materials.
- If the product has been stored for more than a year, it is necessary to have it inspected and tested by professionals before putting it into operation.

NOTICE

It is crucial to store the ESS in accordance with the specified storage requirements. Failure to meet these requirements may result in product damage, and it's important to note that such damage caused by improper storage is not covered by the warranty. To ensure the safekeeping of the ESS and maintain warranty coverage, please adhere to the storage guidelines provided.

5 Mechanical Mounting

WARNING

Respect all local standards and requirements during mechanical installation.

5.1 Safety during Mounting

DANGER

Make sure there is no electrical connection before installation. Before drilling, avoid the water and electricity wiring in the wall.

WARNING

The performance of the system can be affected by an inadequate installation environment. To optimize system performance, please consider the following:

- Install the ESS in a well-ventilated area to promote proper airflow and heat dissipation.
- Ensure that the heat dissipation system or vents of the ESS are not obstructed by objects or debris.
- Avoid installing the ESS in environments where flammable or explosive materials are present, as well as areas prone to smoke accumulation.

CAUTION

Improper handling may cause personal injury!

- When moving the ESS, be aware of its weight and keep the balance to prevent it from tilting or falling.
- Wear proper protective equipment before performing operations on the ESS.
- The bottom terminals and interfaces of the ESS cannot directly contact the ground or other supports.
The ESS cannot be directly placed on the ground.

By following these guidelines, you can help maintain an optimal installation environment and ensure the reliable performance of the ESS.

5.2 Location Requirements

To ensure safe operation, long service life, and expected performance, it is important to select an optimal mounting location for the ESS. Consider the following guidelines:

- The ESS, if it has a protection rating of IP65, can be installed both indoors and outdoors, providing flexibility in choosing the mounting location.
- Install the ESS in a location that allows for easy electrical connection, operation, and maintenance. This will facilitate access to the ESS for any necessary maintenance or troubleshooting tasks.

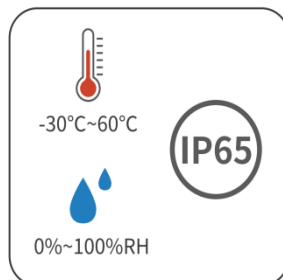

5.2.1 Environment Requirements

- Ensure an installation environment free from flammable or explosive materials.
- Choose a location that is not accessible to children to ensure their safety.
- Ensure that the ambient temperature and relative humidity of the installation site meet the specified requirements.
- To prolong the service life of the ESS, avoid direct exposure to sunlight, rain, and snow. Consider installing them in sheltered areas to provide protection from these elements.



- Ensure proper ventilation for the ESS with adequate air circulation.
- Due to operational noise, it is not recommended to install the ESS in living areas.

5.2.2 Carrier Requirements

The mounting structure for the ESS must adhere to local/national standards and guidelines. The installation surface should be sufficiently sturdy to support four times the weight of the ESS and be suitable for its dimensions (e.g., cement walls, plasterboard walls, etc.).

5.2.3 Angle Requirements

The ESS should be installed in a vertical position. It should never be installed horizontally, tilted forward or backward, or upside down.

5.2.4 Clearance Requirements

Allow ample clearance around the ESS to ensure proper heat dissipation. Install the ESS at a suitable height for convenient viewing of the LED indicator and easy access to the operating switch(es).

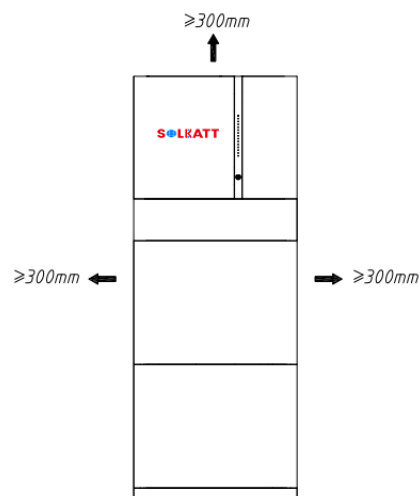

5.3 Installation Tools

Installation tools include but are not limited to the following recommended ones. If necessary, use other auxiliary tools on site

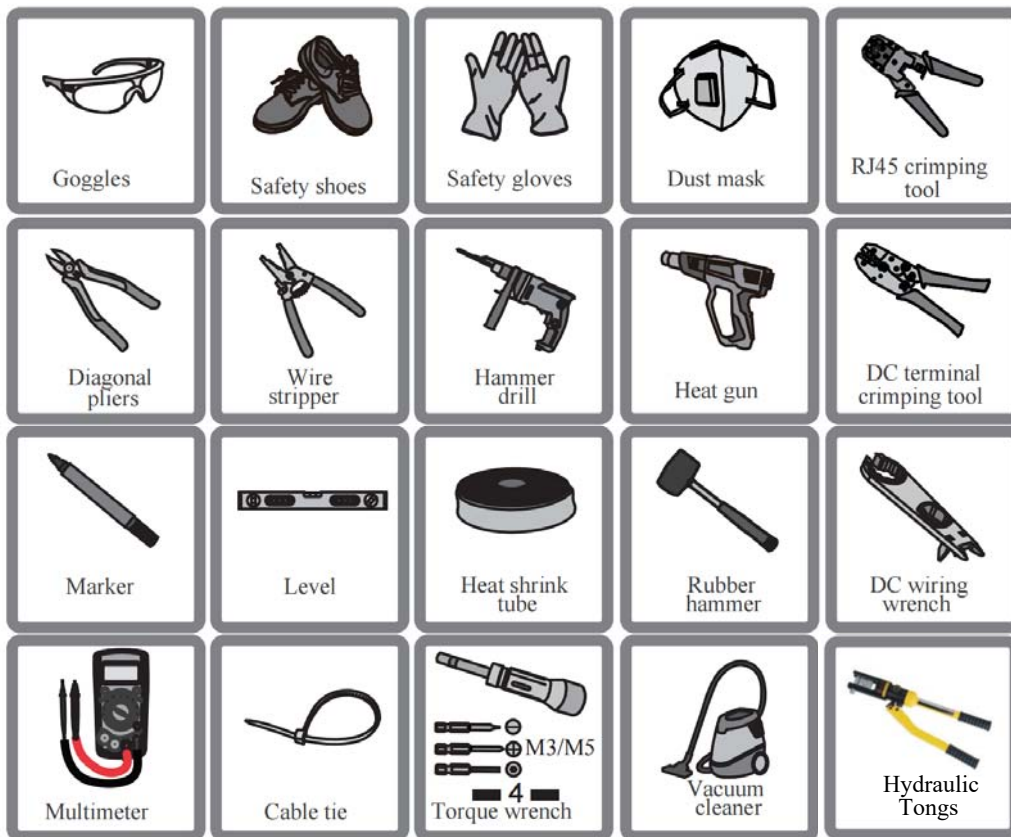

5.4 Moving the ESS

When transferring the ESS to the installation location, please adhere to the subsequent guidelines:

- Maintain constant awareness of the ESS's weight.
- Employ the handles situated on both sides of the ESS to lift it.
- Mobilize the ESS with the assistance of one or two individuals or with the aid of an appropriate transportation device.
- Ensure that the equipment is securely fastened before releasing it.

CAUTION

Please exercise caution to prevent personal injuries while handling the ESS. Adhere to the following guidelines:

- Ensure an adequate number of personnel are assigned to carry the ESS based on its weight, and installation personnel should wear appropriate protective gear like impact-resistant shoes and gloves.
- Take note of the ESS's center of gravity to prevent tilting during handling.
- Avoid placing the ESS directly on a hard surface, as it may damage the metal enclosure. Instead, use protective materials such as a sponge pad or foam cushion underneath the ESS.
- When moving the ESS hold it by the designated handles and avoid gripping the terminals for transportation.

5.5 Installing the ESS

Note:

This ESS should be installed battery modules first on the bottom and then inverter module on the top.

Step 1: Open the cardboard box to remove the battery module and inspect the accessories. Lay the battery pack flat, connect the base to the battery pack with 4 screws.

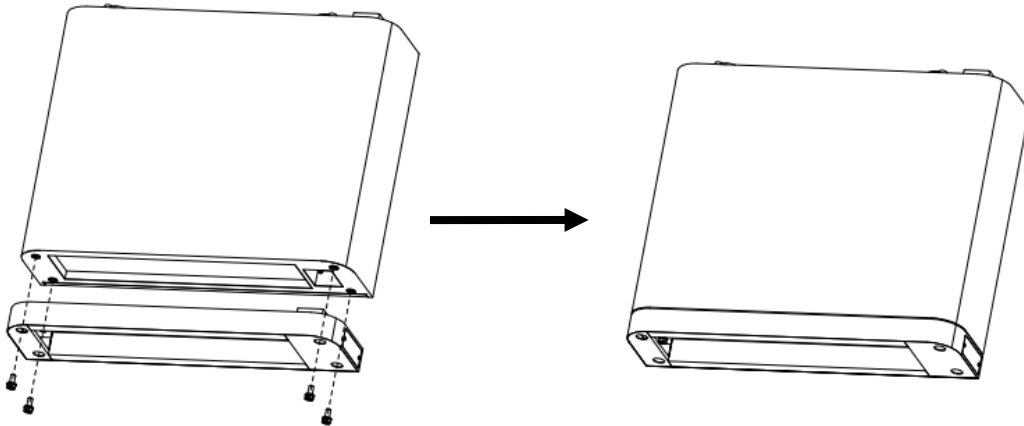

Step 2: Place the battery pack vertically and install 4 positioning pins on the battery pack. Install the battery pack wall mount bracket using 4 screws. After installing the battery wall bracket, place the battery pack against the wall, mark the position that needs to be fixed, move the battery assembly to another position, and then use an impact drill to drill a hole with a diameter of 8mm, insert an expansion screw and lock it.

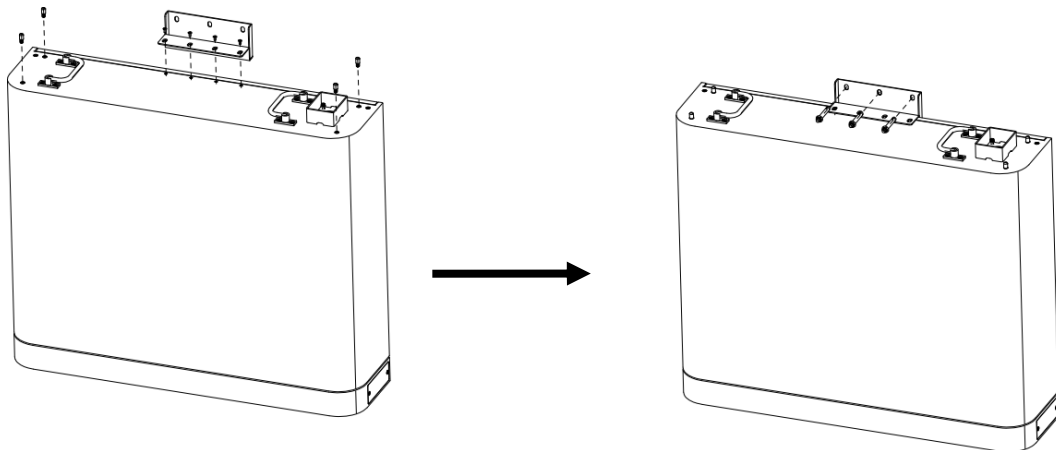

Step 3: Place the second battery pack on top of the first battery pack according to the positioning pin position (if there is only one pack, please ignore this step).

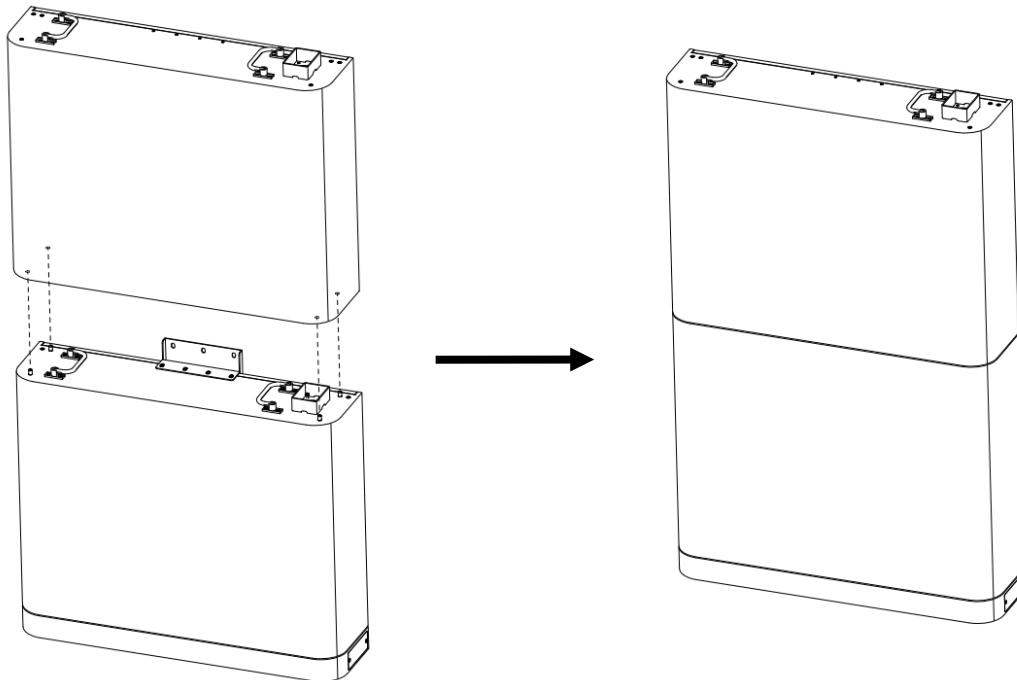

Step 4: Place the battery pack against the wall, align it with the original expansion screw hole, and use 4 screws to install the wall mount bracket for the inverter part of the battery pack. After installing the battery wall bracket, mark the position that needs to be fixed, move the battery assembly to another position, and then use an impact drill to drill a hole with a diameter of 8mm, insert an expansion screw and lock it.

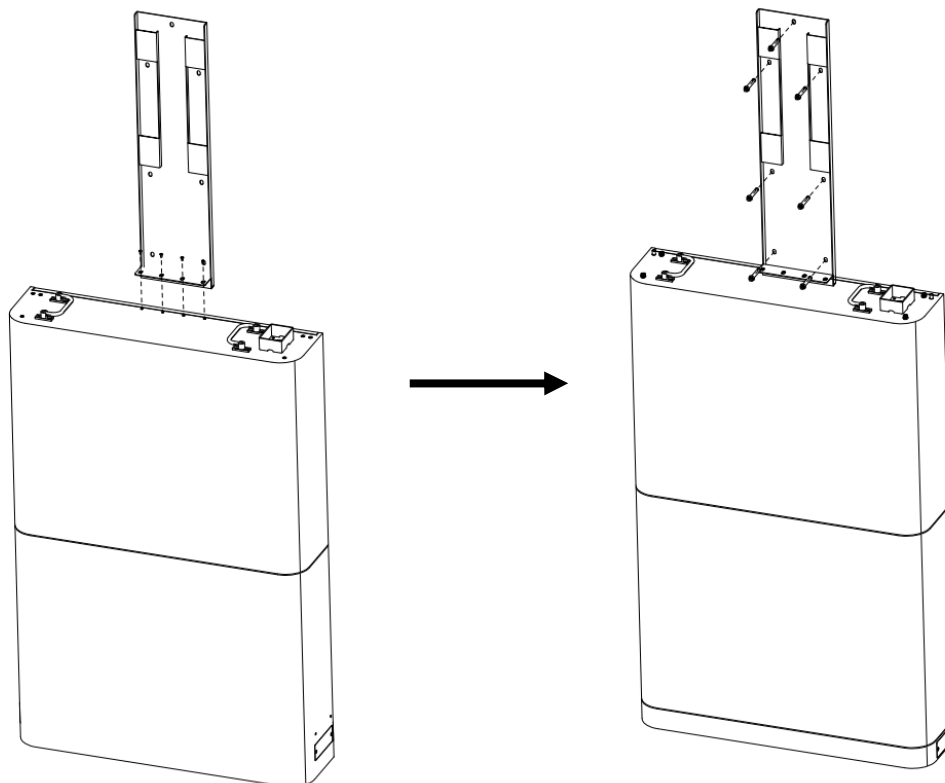

Step 5: Please remove the lower maintenance cover of the inverter horizontally. Then hang the hook on the back of the inverter onto the wall bracket and place it on top of the battery pack. Use 4 screws to lock the inverter onto the battery pack. Install and lock two locating pins.

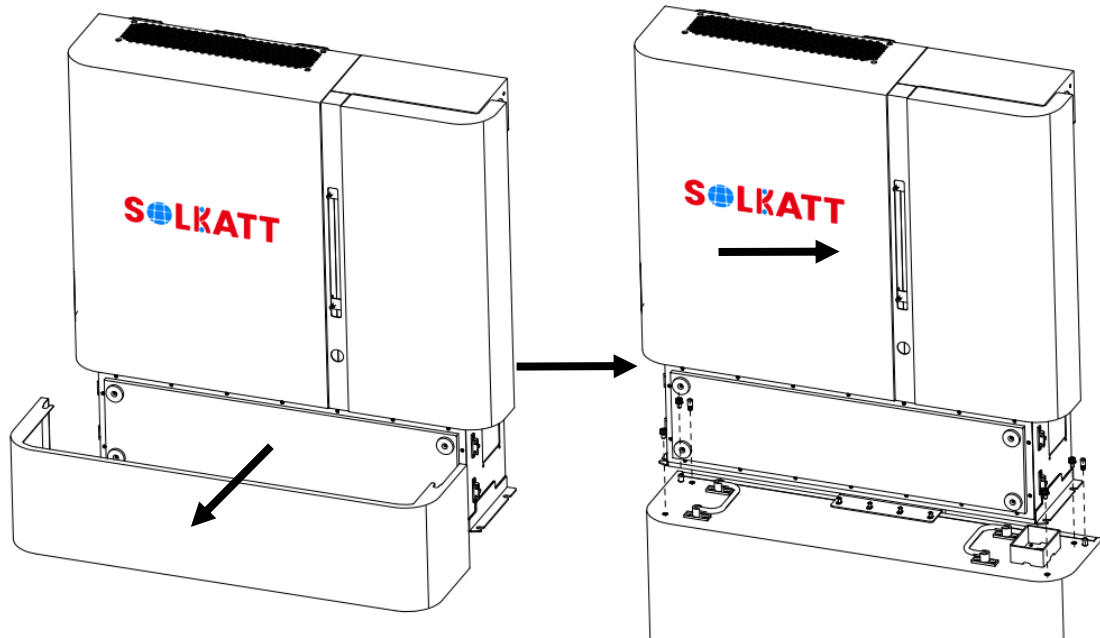

Step 6: Please horizontally install the lower maintenance cover of the inverter back.

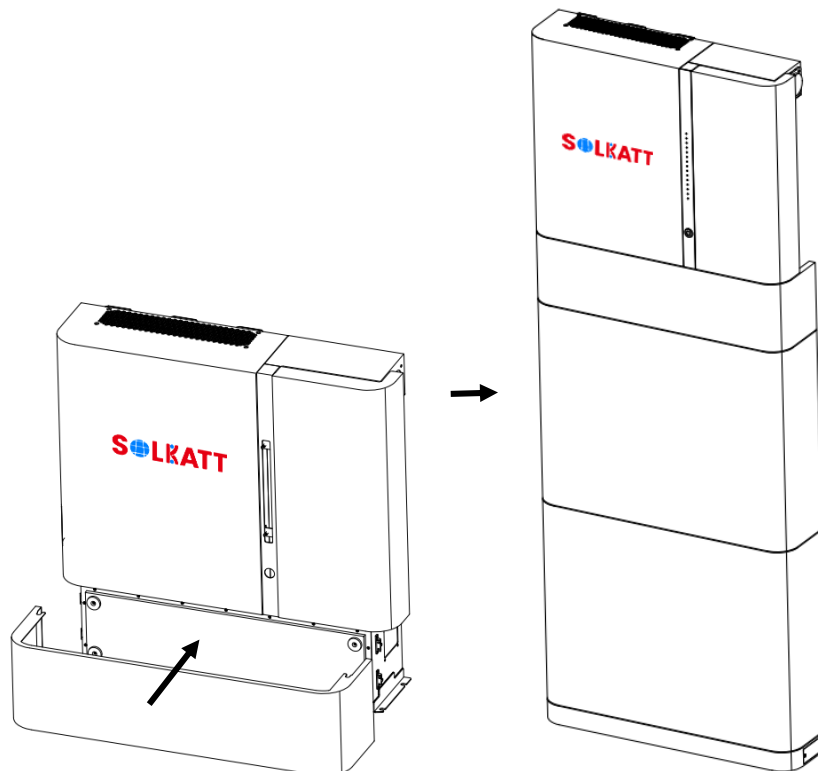

6 Electrical Connection

6.1 Safety Instructions

DANGER

The PV string produces extremely high voltage when exposed to sunlight, which can be lethal. Operators must wear appropriate personal protective equipment during electrical connections. Before touching any DC cables, ensure that they are voltage-free using a measuring instrument. Follow all safety instructions provided in the relevant documents regarding PV strings.

DANGER

- Prior to electrical connections, ensure that the ESS switch and all switches connected to the ESS are set to the "OFF" position to avoid the risk of electric shock.
- Verify that the ESS is undamaged and all cables are voltage-free before performing any electrical work.
- Do not close the AC circuit breaker until the electrical connection is complete.

WARNING

Product damage resulting from incorrect wiring is not covered by the warranty.

- Electrical connections should only be carried out by professionals.
- Operators must wear proper personal protective equipment during electrical connections.
- All cables used in the PV generation system must be securely attached, adequately insulated, and correctly sized.

NOTICE

All electrical connections must adhere to local and national/regional electrical standards.

- Cables used by the user must comply with the requirements of local laws and regulations.
- Connection of the ESS to the grid requires permission from the national/regional grid department.

NOTICE

- All unused terminals must be covered with waterproof covers to maintain the protection rating.
- After completing the wiring, seal the cable inlet and outlet holes with fireproof/waterproof materials such as fireproof mud to prevent the entry of foreign matter or moisture, which may affect the long-term operation of the ESS.
- Adhere to the safety instructions related to PV strings and the regulations concerning the utility grid.

Note:

1. The cable colors shown in the figures in this manual are for reference only. Select cables according to the local cable standards.
2. Before connecting all wires, be sure that side covers of inverter and battery modules are removed. This step should be executed before modules are installed to the wall.

6.2 The battery module connects to the inverter

6.2.1 Terminal Description

All electrical terminals are located on the side of the inverter.

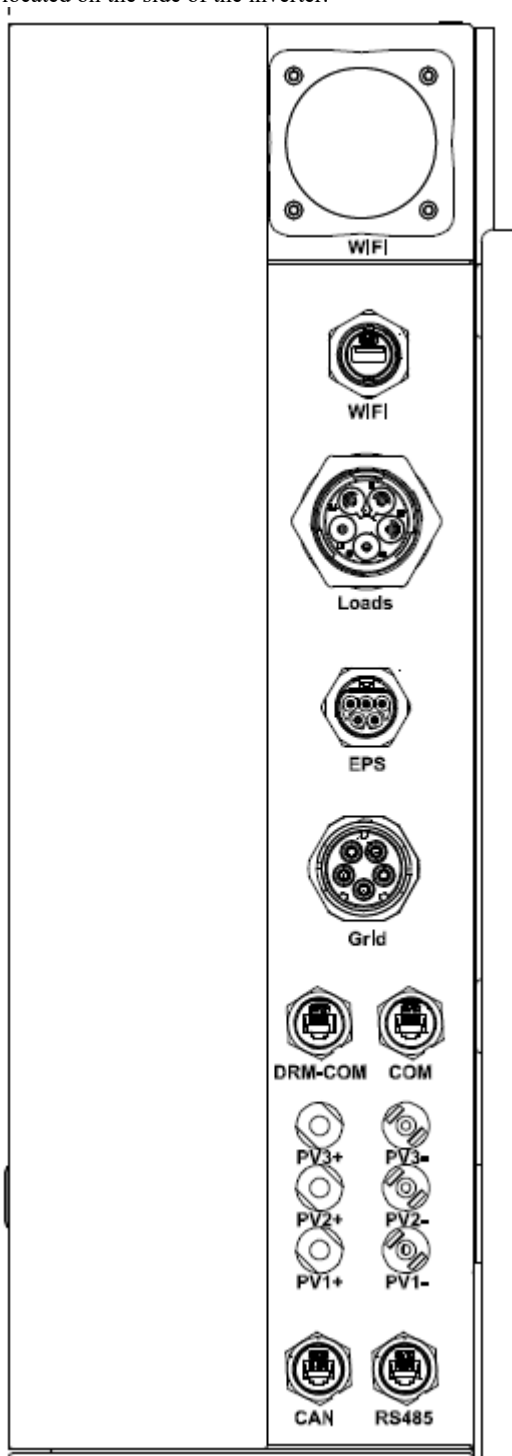

6.2.2 Connecting the AC Cable

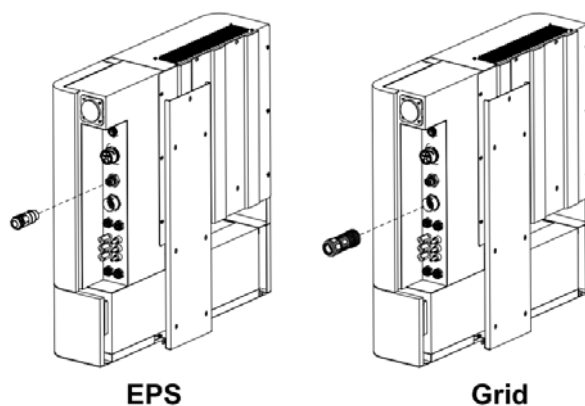

6.2.2.1 Grid + EPS connection

GRID connection is the three- phase-four-wire grid + EPS connection (L1, L2, L3, N, and PE).

step 1 Follow step 1\2\3\4\5 to unscrew the swivel nut of the connector.

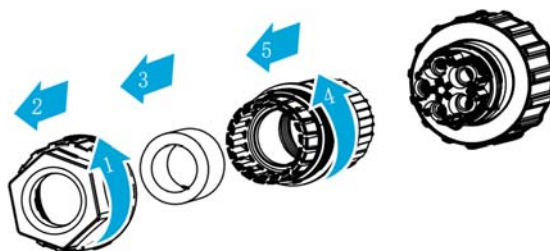

step 2 Strip 40 mm of the cable jacket and 12 mm(L) of the wire insulation.

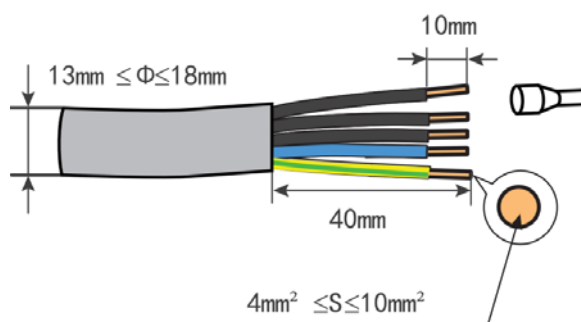

step 3 Follow Step 1\2\3 to tighten the GRID\EPS terminal nut back, And press all wires onto the tubular terminals

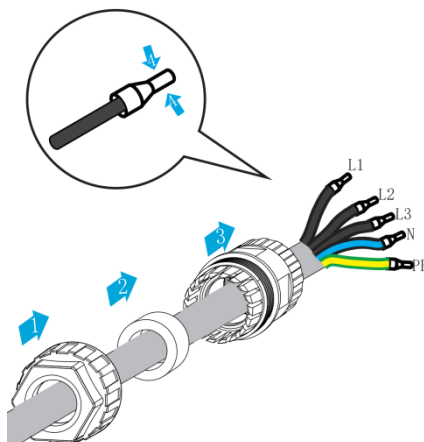

step 4 Connect L1\L2\L3\N\PE to the corresponding position of the GRID\EPS terminal and tighten it with the corresponding tool;

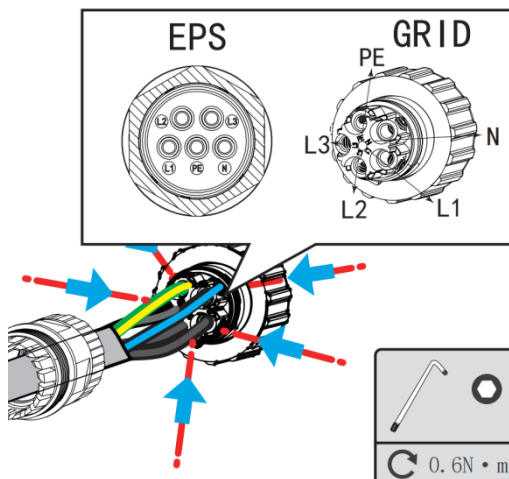

step 5 Follow Step 1\2 to insert the terminals into the inverter grid socket.

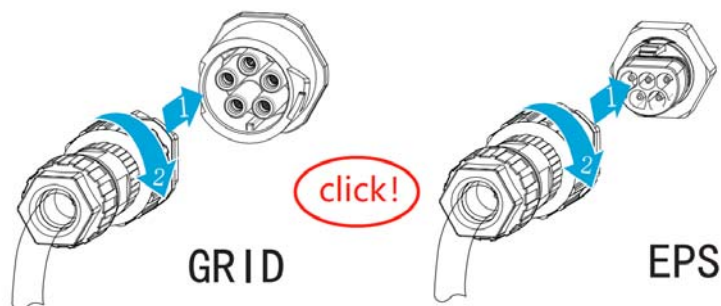

6.2.2.2 Loads connection

Loads connection is the three- phase-four-wire Loads connection (L1, L2, L3, L4, and PE).

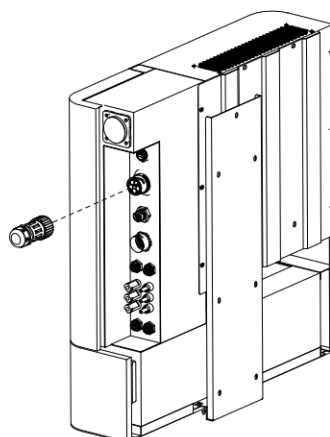

Loads

step 1 Follow step 1\2\3\4\5 to unscrew the swivel nut of the connector.

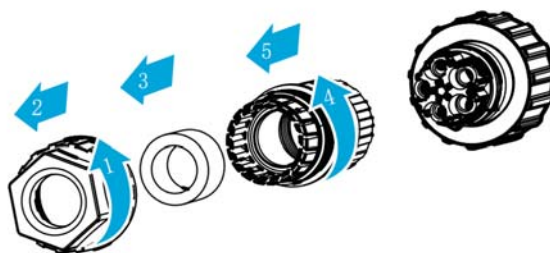

step 2 Strip 40 mm of the cable jacket and 12 mm(L) of the wire insulation.

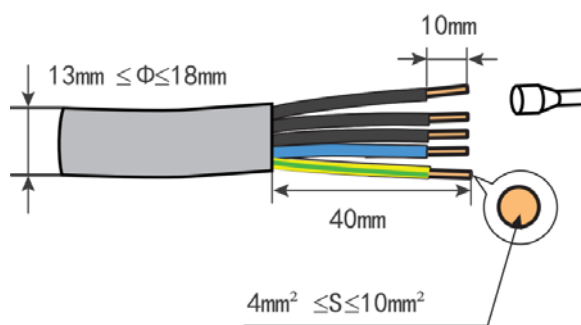

Step 3 : Assemble the cable ends with hydraulic pliers.



Step 4: Connect L1 \ L2 \ L3 \ L4 \ PE to the corresponding position of the Load terminal and insert it.



Step 5: After inserting the male head with the socket, tighten the middle sleeve; Tighten the nut.



6.3 DC Cable Connection

DANGER

The PV string will generate lethal high voltage when exposed to sunlight.

- Respect all safety instructions listed in relevant documents about PV strings.

WARNING

- Make sure the PV array is well insulated to ground before connecting it to the inverter.
- Make sure the maximum DC voltage and the maximum short circuit current of any string never exceed inverter permitted values specified in "Technical Data".
- Check the positive and negative polarity of the PV strings, and connect the PV connectors to corresponding terminals only after ensuring polarity correctness.
- During the installation and operation of the inverter, please ensure that the positive

or negative electrodes of PV strings do not short-circuit to the ground. Otherwise, an AC or DC short-circuit may occur, resulting in equipment damage. The damage caused by this is not covered by the warranty.

- Electric arc or contactor over-temperature may occur if the PV connectors are not firmly in place, and we shall not be held liable for any damage caused.
- If the DC input cables are reversely connected or the positive and negative terminals of different MPPT are shorted to ground at the same time, while the DC switch is in the "ON" position, do not operate immediately. Otherwise, the inverter may be damaged. Please turn the DC switch to "OFF" and remove the DC connector to adjust the polarity of the strings when the string current is lower than 0.5A.

WARNING

Before connecting the PV array to the inverter, ensure that the impedances between the positive terminals of the PV string and earth, and between the negative terminals of the PV string and earth are larger than 1 M Ohm.

NOTICE

The following requirements about PV string connection must be met. Otherwise, it may cause irreversible damage to the inverter, which is not covered by the warranty.

- Mixed use of different brand or model of PV modules in one MPPT circuit, or PV modules of different orientation or angles in a string may not damage inverter but will cause system bad performance!

6.3.1 PV Input Configuration

In Australia and New Zealand, ensure the DC power for any PV string never exceeds a certain level with regards to the string voltage to avoid derating:

- < 12.5 kW if string voltage is lower than 500 V
- < 10 kW if string voltage is between 500 V and 800 V
- < 8 kW if string voltage is between 800 V and 1000 V

For 10kW-3P, each pair of PV terminals is corresponding to an independent PV string. PV input PV1 connect to MPPT1 and PV2, PV3 connect to MPPT2. For the best use of PV power, PV2 and PV3 should be the same in PV string structure, including the type, number, tilt, and orientation of the PV modules.

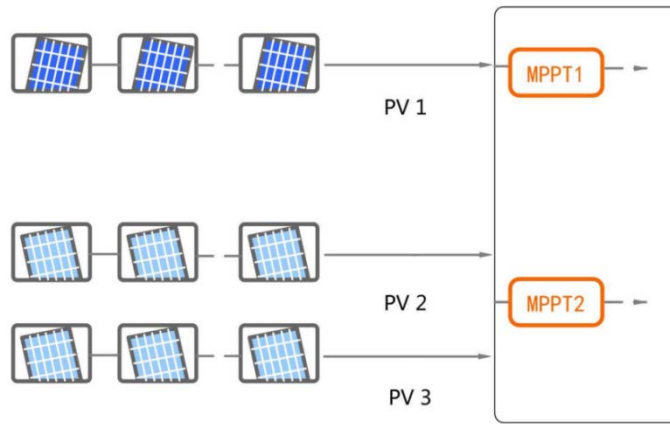

For 10kW-3P, if two PV strings are paralleled externally, the paralleled strings can be connected to PV2 or PV3 only, and the other one cannot be used to connect other PV strings.

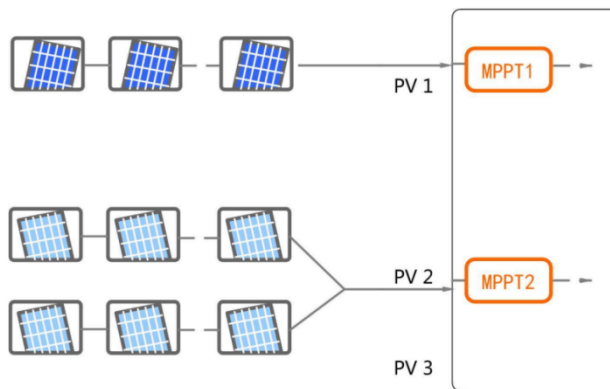

Prior to connecting the inverter to PV inputs, the following electrical specifications must be met Simultaneously.

NO.Model	Open circuit Voltage Limit	Max. Current for Input Connector
10kW-3P	1000V	39A

6.3.2 Assembling the PV Connectors

DANGER

High voltage may be present in the inverter!

- Ensure all cables are voltage-free before performing electrical operations.
- Do not connect the DC switch and AC circuit breaker before finishing electrical connection.

To ensure IP65 protection, use only the supplied connector.

Step1 Strip the insulation from each DC cable by 7 mm-8 mm.

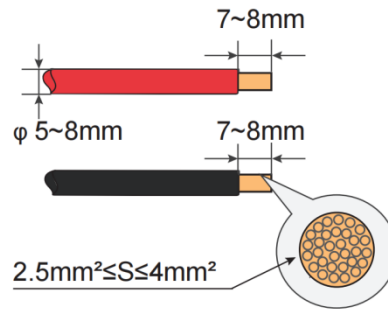

Step 2 Assemble the cable ends with the crimping pliers.

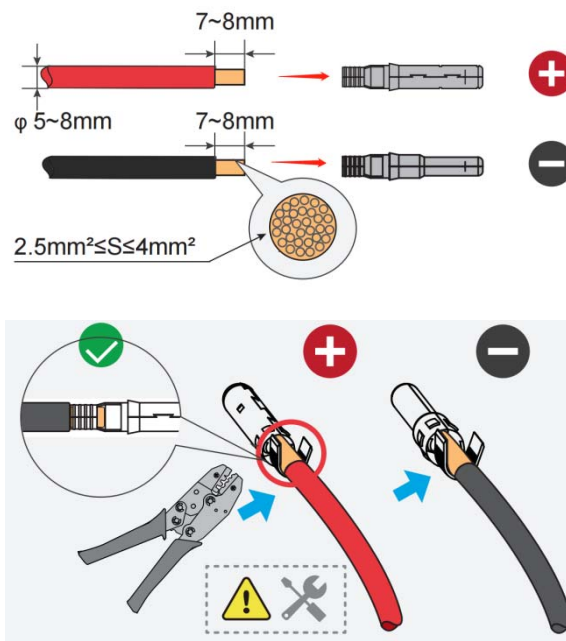

Step 3 Lead the cable through cable gland, and insert the crimp contact into the insulator until it snaps into place. Gently pull the cable backward to ensure firm connection. Tighten the cable gland and the insulator (torque 2.5 N.m to 3 N.m).



step 4 Check for polarity correctness.

NOTICE

If the PV polarity is reversed, the inverter will be in a fault or alarm state and will not operate normally.

6.3.3 Installing the PV Connector

Step 1 Rotate the DC switch to "OFF" position.

Step 2 Check the cable connection of the PV string for polarity correctness and ensure that the open circuit voltage in any case does not exceed the inverter input limit of 1,000V.

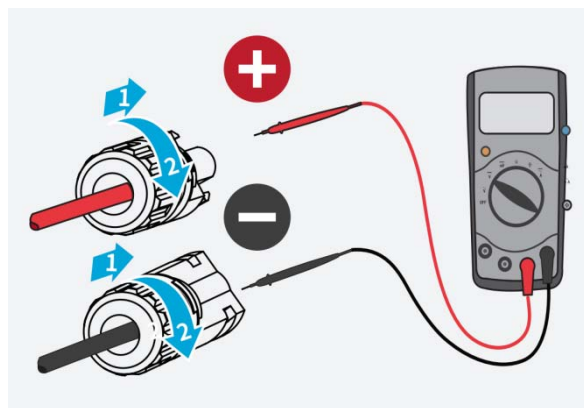

Step 3 Connect the PV connectors to corresponding terminals until there is an audible click.

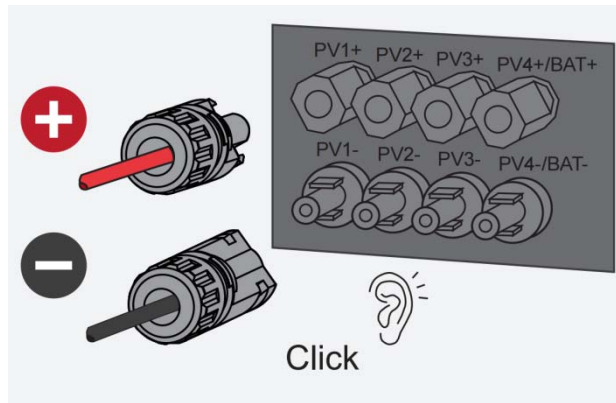

step 4 Follow the foregoing steps to connect PV connectors of other PV strings.

step 5 Seal any unused PV terminal with a terminal cap.

If the PV string is equipped with the optimizer, please refer to the optimizer manual for electrical connections and make sure that the polarity of the optimizer cables is correct.

6.4 WLAN- RS485 Connection

The WLAN-RS485 module can upload the running information of the inverter to the corresponding APP, so that users can check the running status of the inverter at any time. The following figure shows the connection mode

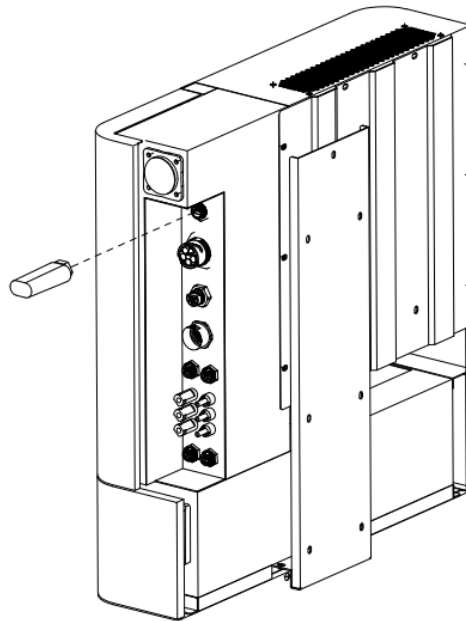

6.5 Inverter communication definition

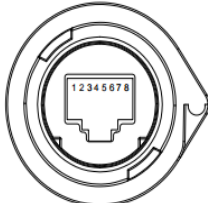

DRM-COM

NO.	Function
1	COM/DRMO
2	3V3_DRM
3	DRM4/8
4	DRM3/7
5	DRM2/6
6	DRM1/5
7	NC
8	NC

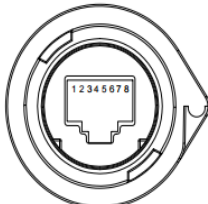

COM

NO.	Function
1	RSD_2
2	RSD_1
3	BACKUP_RS485_B
4	BACKUP_RS485_A
5	BAT_CAN_H
6	BAT_CAN_L
7	NC
8	NC

6.6 Battery communication definition

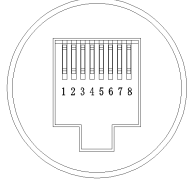
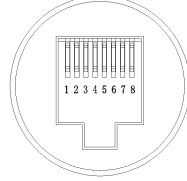
Communication with	RS485B interface 	RS485-8P8C			
		RJ45 Pin	Definition Description	RJ45 Pin	Definition Description
host computer		1	RS485B_B	5	NC
		2	RS485B_A	6	NC
		3	NC	7	RS485B_A
		4	NC	8	RS485B_B
External communication	CAN And RS485A interface 	CAN-8P8C			
		RJ45 Pin	Definition Description	RJ45 Pin	Definition Description
		1	RS485A_B	5	CAN_L
		2	RS485A_A	6	NC
		3	NC	7	RS485A_A
		4	CAN_H	8	RS485A_B

7 Commissioning

7.1 Inspection before Commissioning

Before starting the ESS, please ensure the following checklist items are checked:

- Confirm that all equipment has been installed securely and in accordance with the manufacturer's instructions.
- Verify that the DC switch(es) and AC circuit breaker are in the "OFF" position.
- Ensure that the ground cable is properly and securely connected.
- Check that the AC cable is correctly and reliably connected.
- Verify that the DC cable is properly and securely connected.
- Confirm that the communication cable is properly and securely connected.
- Seal any vacant terminals to prevent dust or moisture ingress.
- Ensure that no foreign items, such as tools, are left on top of the machine or inside the junction box (if applicable).
- Verify that the AC circuit breaker is selected according to the requirements specified in the manual and local standards.
- Check that all warning signs and labels on the ESS are intact and legible.

It is essential to complete these checks before starting the ESS to ensure safe and reliable operation.e.

7.2 Powering on the System

If all the checklist items have been verified and meet the requirements, follow these steps to start up the ESS for the first time:

Step 1: Turn on the AC circuit breaker located between the ESS and the grid.

Step 2: Rotate the DC switch to the "ON" position.

Step 3: If the irradiation and grid conditions meet the requirements, the ESS will start operating normally. Observe the LED indicator on the ESS to ensure it is functioning properly. Refer to the "2.1 LED Panel" section of the manual for an introduction to the LED screen and its indicator definitions.

Step 4: If using the SOLARMAN Smart system, refer to the quick guide for its indicator definitions.

By following these steps, you can safely start up the ESS and begin its normal operation.

--End

7.3 Download App

If you are a residential user, please scan the QR code provided below to download the SOLARMAN Smart app. Alternatively, you can visit the website <https://home.solarmanpv.com> to access the app.



SOLARMAN Smart

7.4 Registration

Go to SOLARMAN Smart and sign up.

Click on "Sign up" and create your account here. Please note that use an email address to register for an account.

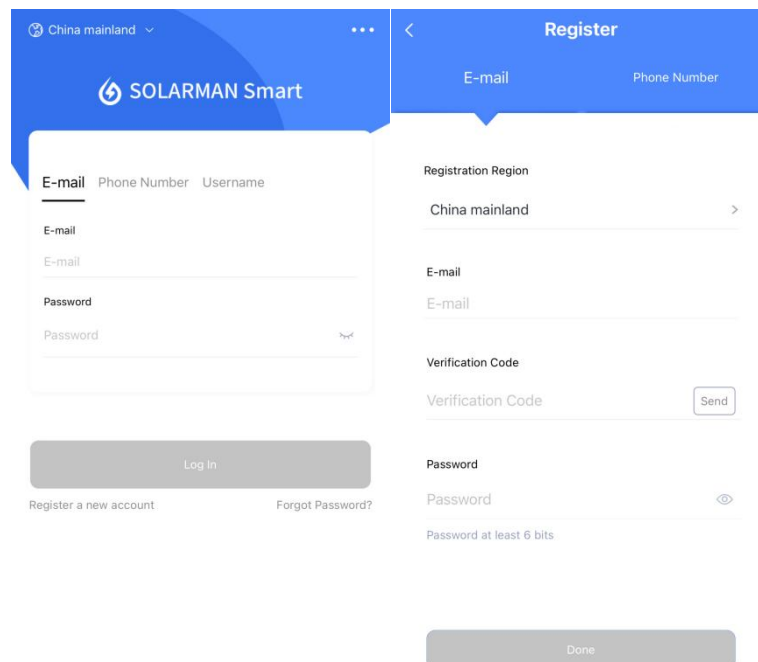

The screenshot shows the SOLARMAN Smart registration interface. The top bar is blue with the SOLARMAN Smart logo and the text "China mainland". Below the logo, there are three tabs: "E-mail", "Phone Number", and "Username". The "E-mail" tab is selected. The registration form includes the following fields and options:

- Registration Region:** A dropdown menu showing "China mainland" with a right arrow.
- E-mail:** A text input field with "E-mail" placeholder text.
- Verification Code:** A text input field with "Verification Code" placeholder text and a "Send" button to the right.
- Password:** A text input field with "Password" placeholder text and an eye icon to toggle visibility. Below the field, it says "Password at least 6 bits".

At the bottom of the form, there is a "Done" button. On the left side of the interface, there is a "Log In" button and links for "Register a new account" and "Forgot Password?".

7.5 Create a Plant

Click "Add Now" to create your solar installation.

Please provide the necessary information about your solar plant, including basic details and any additional relevant information.

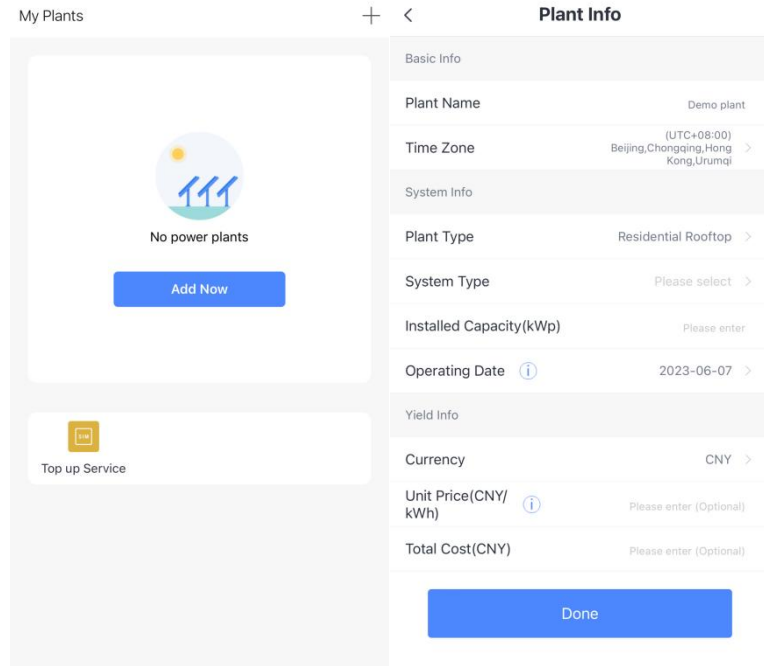

7.6 Add a Logger

- step 1 Manually enter the serial number (SN) of the logger.
 - step 2 Click on the icon located on the right side and scan the barcode to enter the logger serial number.
- You can locate the logger serial number on the external packaging or on the body of the logger itself.

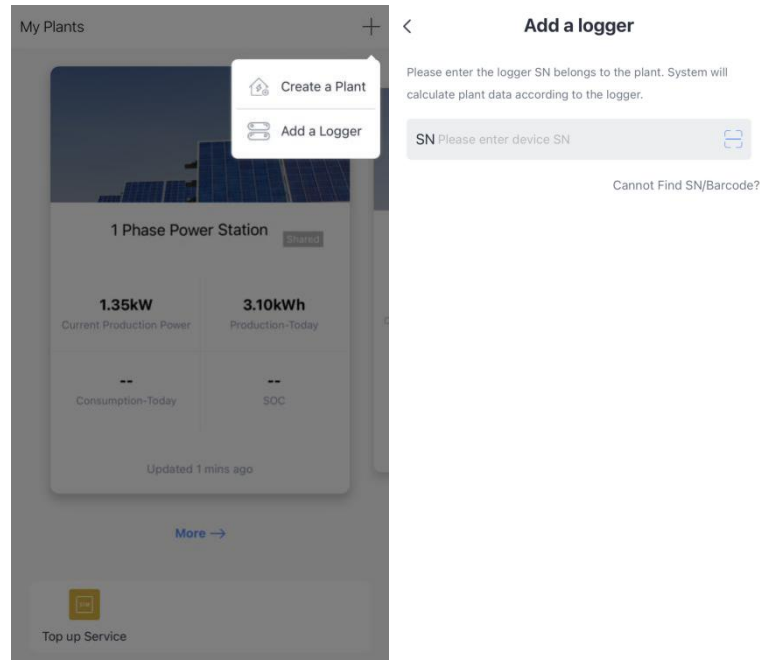

7.7 Network Configuration

- Step 1: Click on "Go to Configure" to access the network settings.
- (Ensure that Bluetooth and WiFi are turned ON.)

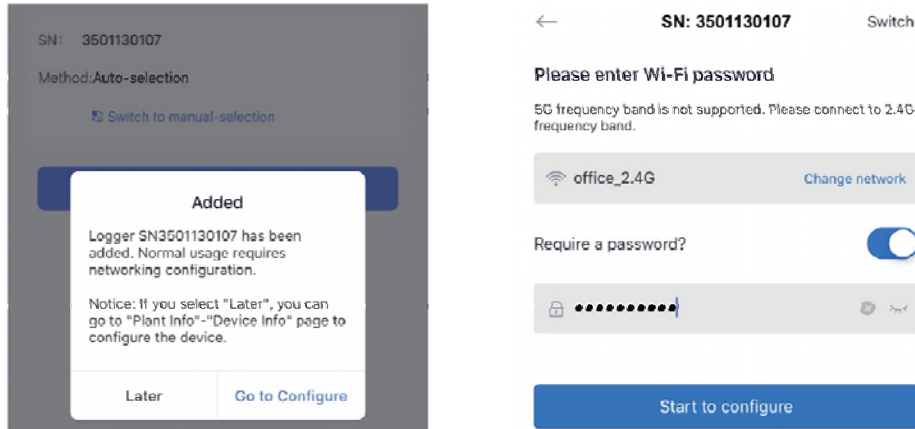

Step 2: Please wait for a few minutes. Afterward, click on "Done" to complete the setup and view the plant data.

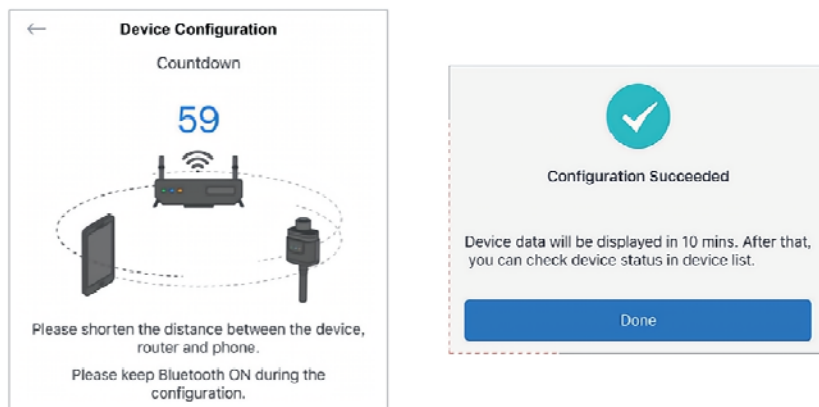

Notice:
5G WiFi is not supported.

If the configuration process fails, please check the following reasons and attempt the setup again:

- (1) Ensure that WLAN (Wireless Local Area Network) is turned on.
- (2) Verify that your WiFi connection is functioning properly.
- (3) Confirm that the wireless router does not have any restrictions in place, such as a white-black list.
- (4) Remove any special characters from the Wi-Fi network name (SSID) or password.
- (5) Reduce the distance between your phone and the device during the configuration process.
- (6) Try connecting to a different Wi-Fi network if available.

Warning: Before leaving the site, it is crucial to ensure that the stick logger is functioning correctly. If you notice any abnormal behavior or issues, please refrain from leaving the site and immediately contact customer service. You can reach customer service at the following number: 400-181-0512

7.8 Stick Logger Installation

Assemble the logger to the ESS communication interface according to the diagram provided..

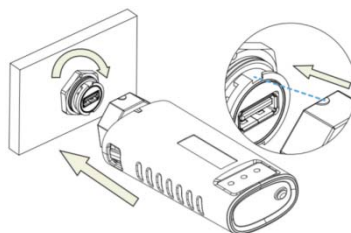

7.9 Logger Status

7.9.1 Check Indicator light

Lights	Implication	Status Description (All lights are single green lights.)
NET	Communication with router	<ol style="list-style-type: none"> 1. Light off: Connection to the router failed. 2. On 1s/Off 1s (Slow flash): Connection to the router succeeded. 3. Light keeps on: Connection to the server succeeded. 4. On 100ms/Off 100ms (Fast flash): Distributing network fast.
COM	Communication with inverter	<ol style="list-style-type: none"> 1. Light keeps on: Logger connected to the inverter. 2. Light off: Connection to the inverter failed. 3. On 1s/Off 1s (Slow flash): Communicating with inverter.
READY	Logger running status	<ol style="list-style-type: none"> 1. Light off: Running abnormally. 2. On 1s/Off 1s (Slow flash): Running normally. 3. On 100ms/Off 100ms (Fast flash): Restore factory settings.

When the router is connected to the network normally, the stick logger should exhibit the following normal operation status:

1. Connection to the server succeeded: The NET light will remain illuminated after the logger is powered on.
2. Logger running normally: The READY light will flash intermittently.
3. Connection to the ESS succeeded: The COM light will remain illuminated..

7.10 Abnormal State Processing

If you encounter abnormal data on the platform while the stick logger is running, please refer to the following table and use the status of the indicator lights to perform basic troubleshooting. If the issue persists or if the indicator lights' status is not listed in the table, please contact Customer Support for assistance.

(Note: Use the table below after the stick logger has been powered on for at least 2 minutes.)

NET	COM	READY	Fault Description	Fault Cause	Solution
Any state	OFF	Slow flash	Communicate with inverter abnormally	<ol style="list-style-type: none"> 1. Connection between stick logger and inverter loosen. 2. Inverter does not match with stick logger's communication rate 	<ol style="list-style-type: none"> 1. Check the connection between stick logger and inverter. Remove the stick logger and install again. 2. Check inverter's communication rate to see if it matches with stick logger's. 3. Long press Reset button for 5s, reboot stick logger.
OFF	ON	Slow flash	Connection between logger and router abnormal	<ol style="list-style-type: none"> 1. Stick logger does not have a network. 2. Router WiFi signal strength weak. 	<ol style="list-style-type: none"> 1. Check if the wireless network configured. 2. Enhance router WiFi signal Strength.
Slow flash	ON	Slow flash	Connection between logger and router normal, connection between logger and remote server abnormal	<ol style="list-style-type: none"> 1. Router networking abnormal. 2. The server point of logger is modified. 3. Network limitation, server cannot be connected. 	<ol style="list-style-type: none"> 1. Check if the router has access to the network. 2. Check the router's setting, if the connection is limited. 3. Contact our customer service.
OFF	OFF	OFF	Power supply abnormal	<ol style="list-style-type: none"> 1. Connection between stick logger and inverter loosen or abnormal. 2. Inverter power insufficient. 3. Stick Logger abnormal. 	<ol style="list-style-type: none"> 1. Check the connection, remove the stick logger and install again. 2. Check inverter output power. 3. Contact our customer service.
Fast flash	Any state	Any state	Networking status	Normal	<ol style="list-style-type: none"> 1. Exit automatically after 2mins. 2. Long press Reset button for 5s, reboot stick logger. 3. Long press Reset button for 10s, restore factory settings.
Any state	Any state	Fast flash	Restore factory settings	Normal	<ol style="list-style-type: none"> 1. Exit automatically after 1mins. 2. Long press Reset button for 5s, reboot stick logger.

					3. Long press Reset button for 10s, restore factory settings.
--	--	--	--	--	---

 **Warning:**
Please do not hold the logger body to rotate while install or remove the logger.



 **Notice:**
Do not remove waterproof plug.



8 System Decommissioning

8.1 Disconnecting the ESS

8.1.1 Disconnecting the ESS

CAUTION

To ensure safety and prevent the risk of burns, it is important to follow proper procedures when operating or performing maintenance on the ESS. Please adhere to the following steps to disconnect the ESS from the AC and DC power sources:

Step 1: Disconnect the external AC circuit breaker that supplies power to the ESS. Make sure to secure it against accidental reconnection.

Step 2: Rotate the DC switch to the "OFF" position to disconnect all PV string inputs from the ESS.

Step 3: Wait for approximately 10 minutes to allow the capacitors inside the ESS to completely discharge. This step is crucial to ensure that no residual electrical charge remains.

Step 4: Use a current clamp to verify that the DC cable is free from any electrical current. This is an important safety measure to prevent any potential shocks or hazards.

Please remember to wear protective gloves when operating the ESS, even after it has been shut down and allowed to cool down. In addition, always follow safety guidelines and refer to the manufacturer's instructions for specific procedures and precautions related to maintenance and service work on the ESS.

--End

8.1.2 Dismantling the ESS

CAUTION

Risk of burn injuries and electric shock!

Do not come into contact with any internal live components until at least 10 minutes have elapsed after disconnecting the ESS from the utility grid and PV input.

Before disassembling the ESS, ensure that both AC and DC connections are disconnected.

Step 1: Disconnect all cables from the ESS in reverse order as described in the "Electrical Connection" section.

Step 2: Disassemble the ESS following the reverse steps outlined in the "Mechanical Mounting" section.

Step 3: If needed, remove the wall-mounting bracket from the wall.

Step 4: If the ESS will be stored for future use, please refer to the "ESS Storage" section for proper conservation guidelines.

--End

8.1.3 Disposal of the ESS

Users are solely responsible for the proper disposal of the ESS.

WARNING

Please ensure that the ESS is disposed of in accordance with the relevant local regulations and standards to prevent any property losses or casualties.

NOTICE

Certain components of the ESS may pose a risk of environmental pollution. Please adhere to the disposal regulations for electronic waste that are applicable at your installation site when disposing of these components.

8.2 Decommissioning the Battery

To decommission a Li-ion battery after the ESS has been decommissioned, follow these steps:

Step 1: Disconnect the DC circuit breaker located between the battery and the ESS.

Step 2: Disconnect the communication cable that connects the battery to the ESS.

Step 3: Wait for approximately 1 minute to allow for any residual voltage to dissipate. Then, use a multimeter to measure the voltage at the battery ports.

Step 4: If the battery port voltage is zero, proceed to disconnect the power cables from the battery module.

Note: It is important to exercise caution and follow proper safety procedures when handling and decommissioning batteries.

--End

CAUTION

We do not assume liability for the disposal of the battery. The responsibility for proper battery disposal rests with the user. Please ensure that the battery is disposed of in accordance with applicable local regulations and standards to avoid any property damage or harm.

9 Appendix

9.1 Technical Data

MODEL	YP-ESS10-8HVS1	YP-ESS10-8HVS2
PV Input		
Recommended max. PV input power	15000 W _p	
Max. PV input voltage	1000V	
Startup input voltage	250V	
Rated PV input voltage	600V	
MPP voltage range	200-950V	
No. of independent MPP inputs	2	
No. of PV strings per MPPT	1\2	
Max. PV input current	48A(16A/32A)	
Short-circuit current of PV input	60A(20A/40A)	
AC Input and Output		
Max. AC power from grid	20600 VA	
Rated AC output power	10000 W	
Max. AC output apparent power	11000 VA	
Rated AC output current	15.2 A	
Max. AC output current	16.7A	
Rated AC voltage	3/N/PE 220V/380V 230V/400V 240V/415V	
AC voltage range	270V-480V	
Rated grid frequency	50Hz/60Hz	
Grid frequency range	45~55Hz/55~65Hz	
Harmonic (THD)(of rated power)	< 3%	
Power factor at Rated power	> 0.99	
Adjustable power factor	0.8 leading to 0.8 lagging	
AC Type	Threephase	
Battery data		
Rate voltage(Vdc)	178.2	356.4
Cell combination	54S1P	54S1P*2
Rate capacity(AH)	50	50
Energy storage(KWH)	8.64	17.28
Cycle life	6000 cycles @80% DOD, 0.5C	
Voltage at end of Discharge(Vdc)	151.2	302.4
Charging Voltage(Vdc)	189	378
Max Charging Current(A)	30A	30A
Max Discharging current(VDC)	30A	30A
Discharge Cut-off voltage(VDC)	135	270
Environment		
Charge temperature	0 °C to 50°C @60±25% Relative Humidity	
Discharge temperature	-20°C to 50 °C @60±25% Relative Humidity	

Storage temperature	-20°C to 50 °C @60±25% Relative Humidity	
Mechanical		
IP class	IP65	
Material system	LiFePO4	
Case material	Metal	
Case Type	All in One Stack	
Size L*W*H(mm)/weight	Assemble: 770*208*1415 (Inverter high-voltage box: 770*205*777 65kg battery box: 770*188*615(single) 88kg)	Assemble: 770*208*1998 (Inverter high-voltage box: 770*205*777 65kg battery box: 770*188*615(single)88kg)
Packaging size /gross weight	Inverter high-voltage box: 865*290*870 67kg battery box: 865*285*678(single) 90kg accessory box: 865*285*225 11kg	Inverter high-voltage box: 865*290*870 67kg battery box: 865*285*678(single)*2 180kg accessory box: 865*285*225 11kg
Communication		
Protocol(Optional)	RS485/RS232, WLAN Optional	
Certificates		
System	UN38.3,MSDS,EN,IEC,NRS, G99	
Cell	UN38.3, MSDS, IEC62619, CE, UL1973, UL2054	